



LITERATURE

PCRX



DAIRYLAND
ELECTRICAL INDUSTRIES

ALWAYS RUGGED. ALWAYS RELIABLE.



INTRODUCTION

The Dairyland PCRX is a solid-state decoupling device commonly used in conjunction with cathodically protected structures.

The PCRX prevents the flow of direct current while simultaneously providing a low impedance grounding current path for steady state induced alternating current, if present. Steady state AC current of up to 45A rms can flow through the device with DC voltage applied within the operating voltage threshold. These products also provide over-voltage protection for both lightning and AC fault current conditions.

The PCRX provides the additional benefit of electronically camouflaging itself from interrupted surveys, including close interval surveys (CIS), preventing the device from contributing to errors in potential readings. Field testing has shown that interrupted surveys can sometimes be impacted by combinations of factors such as pipeline coatings, soil resistivity, and the capacitance of decouplers resulting in excessively electro-negative instant-off values. In most cases the PCRX completely solves this problem. The PCRX camouflages itself to overcome capacitive effects ensuring accurate and timely potential measurements. It does this without sacrificing the rugged over-voltage, AC mitigation, CP isolation, and safety grounding of Dairyland's standard decoupling products. For more information visit www.dairyland.com

DID YOU KNOW?

The PCRX has been certified by Underwriters Laboratories and is certified for use in Class I, Division 2, Groups A, B, C and D hazardous locations. For more information on certifications and listings, visit dairyland.com



Figure 1 below shows actual field data of a CIS waveform under the conditions of no decoupler, conventional decoupler and PCRX installed on a pipeline. Note that the settling response time of the signal with the PCRX in place is almost identical to the response time with no decoupler present.

INSTANT-OFF WAVEFORM COMPARISON Standard Decoupler vs. No Decoupler vs. PCRX

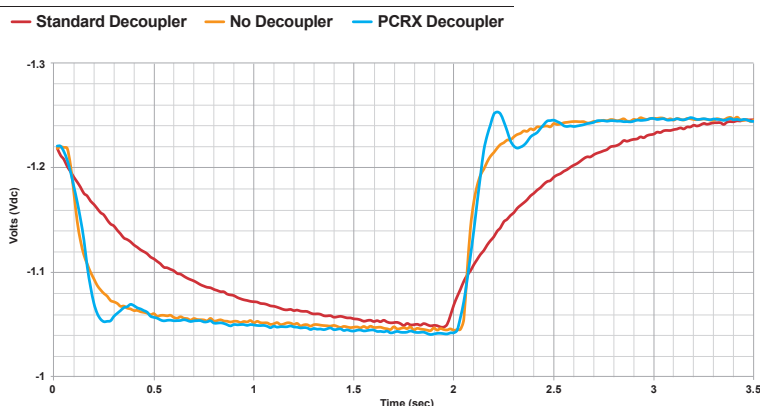

COMMON APPLICATIONS

AC Voltage Mitigation

As an AC mitigation device, the PCRX can collapse the steady-state voltage between the connected points to a negligible level by providing continuous AC grounding for pipelines affected by AC induction while leaving cathodic protection unaffected.

Decoupling Electric Equipment Grounding Systems

When electrical equipment is mounted on a cathodically protected structure, the PCRX can provide DC isolation with fault rated AC continuity. As grounding codes apply, the PCRX is listed by UL for meeting the requirements of an effective AC grounding path per U.S. and Canadian electric codes.

Isolation Joint Protection

Isolation joints often need over-voltage protection against lightning and AC fault exposure, and in some cases, steady-state induced AC voltage. Due to the small clearance between opposite sides of the isolation flange, a protective device must provide a low clamping voltage, including the voltage effects of the conductors or bus bars used to connect the product.

PRODUCT OVERVIEW

AC Fault Current Ratings

Some applications may have conditions where an over-voltage device such as the PCRX is subject to momentary fault current. For this reason, the PCRX was designed to have AC fault current carrying capability. The PCRX will limit the voltage between its connection points to less than 18V peak under the maximum fault current ratings listed below.





Fault current ratings are offered with the following current-time relationship:

AC FAULT CURRENT RATINGS (Amps AC-RMS Symmetrical)			
50/60 Hz Cycles	5kA Model	10kA Model	15kA Model
3	6,800	15,000	27,000
10	5,700	12,000	21,000
30	5,000	10,000	15,000

Note: Verify that the PCRX fault current capability exceeds site conditions. For more information on determining fault current exposure, view our web article: Determining AC Fault Current.

Steady-State AC Current Ratings

This rating represents the maximum steady-state AC 50/60Hz current that is allowed to flow through the device while still blocking the flow of DC current. Exceeding this rating can result in damage to the PCRX.

CONTINUOUS AC CURRENT RATINGS
0 to 45A RMS

The most typical application where a PCRX may be required to block DC current while simultaneously carrying steady-state AC current occurs when a pipeline is in the same corridor as an electrical transmission line, resulting in steady-state AC induction voltage. The PCRX can mitigate this voltage by providing a low AC impedance path for AC current to flow to ground while simultaneously preventing the flow of DC current.

Under an AC fault or lightning current condition, the impedance of the PCRX momentarily becomes virtually zero. For more information on steady-state current view our web article: Measuring Steady-State AC Current

Operating Voltage Rating

The PCRX is available in three different DC operating voltage ratings based on the model number selected. Understanding these ratings is key to the appropriate application of the PCRX. The ratings are -3.0V to +0.5V, -3.5V to +0.5V and -4.5V to +2.0V. These ratings indicate the allowable operating range of the device and are defined as the allowable voltage across the device's terminals while still being able to mitigate the maximum steady state AC current (45A rms).

Blocking Voltage Threshold vs. Operating Voltage

Due to the unique and proprietary operating characteristics of the PCRX, there is a distinct difference between the device's blocking voltage threshold and its operating voltage range. As noted above, the operating voltage range is the DC voltage that may be applied (by CP system) across the device's terminals while still decoupling AC and DC current. In contrast, the device's blocking threshold (also known as its voltage clamping limit) is a wider range of voltage, typically 1.5V beyond the operating limits. The blocking voltage threshold is defined as the voltage at which the device will go into conduction and shunt all current to ground, such as during a fault or lightning event.

The two illustrations below depict the operating nature of the PCRX. These illustrations represent the boundary conditions related to the amount of induced AC current, with one chart representing maximum induced AC current present and its associated 1.5V effect and the other representing no induced AC current, and therefore no additive AC voltage.

Allowable DC operating voltage with 45A AC-rms present

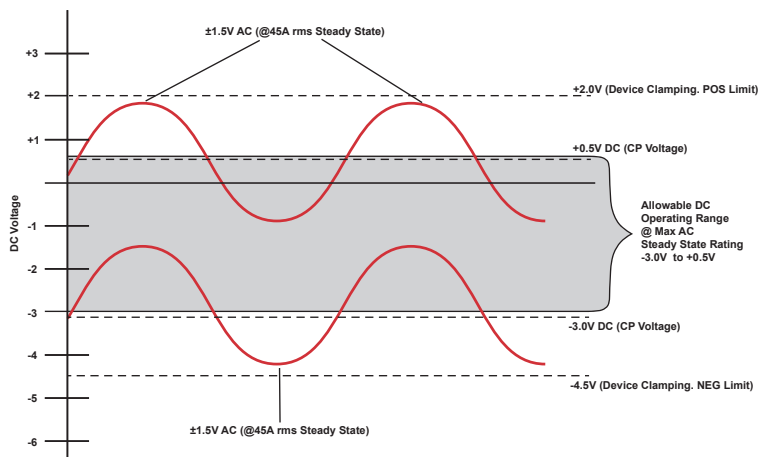

Allowable DC operating voltage with no AC current present

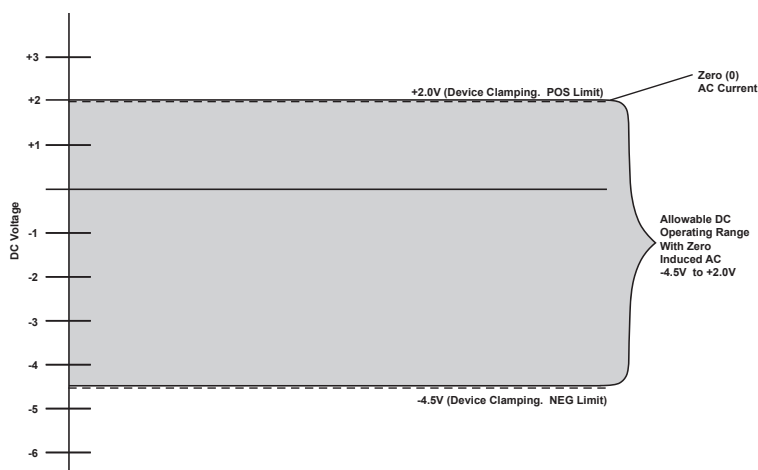

Example:

A PCRX-5KA-3.0/0.5 can have an allowable operating range between -3.0V DC and +0.5V DC applied across its terminals while simultaneously providing a grounding (or coupling) path for the maximum rated steady state AC current of 45A rms. However, if induced AC current was zero, the allowable operating range could expand to between -4.5V DC and +2.0V DC applied, which is the full blocking voltage threshold. The device will clamp at -4.5V and +2.0V regardless and go into conduction at voltages exceeding these limits, such as during a fault or lightning event



FEATURES AND CERTIFICATIONS

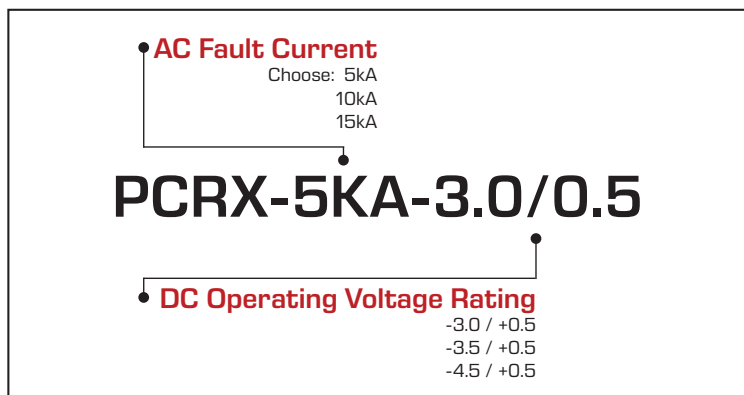

The model number is indicative of the minimum range of applied DC voltage across its terminals and is done so to minimize the chances that the unit would go into conduction earlier or more often than intended.

To further illustrate, the following chart indicates the allowable DC operating range as a function of induced AC.

DC Operating Voltage Rating (AC rms)		
Model Number	Induced AC Steady State	DC Operating Range
PCRX-XXX-3.0/0.5	45A rms	-3.0V...+0.5V
	0A rms	-4.5V...+2.0V
PCRX-XXX-3.5/0.5	45A rms	-3.5V...+0.5V
	0A rms	-5.0V...+2.0V
PCRX-XXX-4.5/0.5	45A rms	-4.5V...+0.5V
	0A rms	-6.0V...+2.0V

Lightning Impulse Current Rating

All models have the same lightning surge current rating which is shown in the following table.

LIGHTNING IMPULSE CURRENT RATING
Peak Amperes: 100kA
8x20 microsecond waveform

KEEP THE CONDUCTORS SHORT!

The PCRX is designed to keep the voltage between the device terminals to a limited value. During lightning conditions, a more important factor than the PCRX voltage clamping capability is the voltage developed in the conductors or bus used to attach the device. Use low inductance bus bars or conductors ideally less than 6 inches (150 mm) long for best results. More information on conductor length is available at www.dairyland.com.

Certifications

The PCRX has been tested by Nationally Recognized Testing Laboratories (NRTLs) for compliance to independent standards in its operation, ratings, and construction. This includes compliance to standards for:

Class I, Div. 2, Groups A, B, C, D and Zone 2, Group IIC.

Class & Division System:
UL (United States) and C-UL (Canada)

- Effective Ground Fault Current Path per:
 - NFPA 70 (US National Electric Code – NEC): Article 250.4(A)(5)
 - CSA C22.1 (Canadian Electric Code, Part I): 10-100 & 10-500
- Isolation of Objectionable DC Ground Currents per:
 - NFPA 70: Article 250.6(E)
 - CSA C22.1: 10-100 & 10-500
- Hazardous Location Use:
 - Class 1, Division 2, Groups A, B,C,D by UL & C-UL per:
 - UL 121201, 9th Ed. and CSA C22.2 No.213-17
- Safety Requirements for Electrical Equipment per:
 - UL 61010-1, 3rd Ed. & CSA C22.2 No. 61010-1
 - Overvoltage Protection from Impulse (Lightning) Current: 100kA (8 x 20µs)
 - Enclosure Rating: NEMA 4X
 - Temperature Range: -40°C to +50°C (-40°F to +122°F)
 - Max Altitude: 2000 meters
 - Ambient Pressure of 80 kPa (0.8 bar) to 110 kPa (1.1 bar)
 - Relative Humidity: 0-100% noncondensing
 - Outdoor use
 - Pollution Degree 2

Zone System: ATEX / IECEx (Europe / International) per ATEX Directive 2014/34/EU (Equipment for use in Potentially Explosive Atmospheres):

- Zone 2, Group IIC, Increased Safety “ec”
- EN IEC 60079-0: 2018
- EN IEC 60079-7: 2015+A1:2018
- IEC 60079-0: 2017
- IEC 60079-7: 2017
- Overvoltage Protection from Impulse (Lightning) Current: 100kA (8 x 20µs)
- Temperature Range: -40°C to +50°C
- Enclosure Rating: IP66



Solid-State Design

The PCRX is built with proven solid-state components which have an instantaneous response with respect to voltage, thereby initiating voltage clamping immediately when the voltage attempts to exceed the blocking level selected.

Fail-Safe

An important safety feature for the PCRX is that if subject to AC fault current or lightning surge current in excess of rating such that failure occurs, failure will occur in the shorted mode. In the shorted mode, the unit can carry greater than rated fault current or lightning surge current and still provide an effective grounding (or conducting) path.

Enclosure

The PCRX enclosure is made of epoxy powder-coated 304 stainless steel suitable for outdoor non-submersible applications and is rated NEMA 4X (comparable to IP 66).

Terminals

Single-hole compact spade terminal connectors are standard.

PCRX terminals have preinstalled 1/2" stainless hardware (bolts, nuts, washers). See Accessories for various attachment options.

Polarity / Electrical Connection

Polarity marks (+) and (-) are provided near the terminals to aid in proper installation. Connect the (-) to the structure with CP or more negative structure and the (+) to the grounded, or more positive, system.

Note: The positive terminal is bonded internally to the metallic enclosure.

Size and Weight

Refer to outline drawings for dimensional data. Packaged weight is approximately 35 pounds (16kg).

Number of Operations

Virtually unlimited under maximum ratings, provided the operations are not immediately repetitive.

Energy Requirements

None. The PCRX does not require an external power source.

MOUNTING OPTIONS

The PCRX is made to mount above grade on a flat surface (e.g., a wood post, unistrut, panel) with up to 5/16" bolts furnished by the user. Pedestal mounting is also an option.

Note: Because of the internal bond between the enclosure and positive terminal, mount the PCRX on a structure not in contact with the cathodically protected structure.

Specific Installation Guidance

The Dairyland website contains detailed information on the installation methods specific to a given application. For wiring diagrams and/or application guidance, see Dairyland Applications.

REVISIONS				
REV	CRCO	DESCRIPTION	REV. BY	REV. DATE
A		PRODUCTION RELEASE	MAD	3/27/2020
B	188	UPDATE MOUNTING HOLE SIZE - 8X ϕ .344 THRU WAS 8X ϕ .313 THRU	MAD	9/3/2020

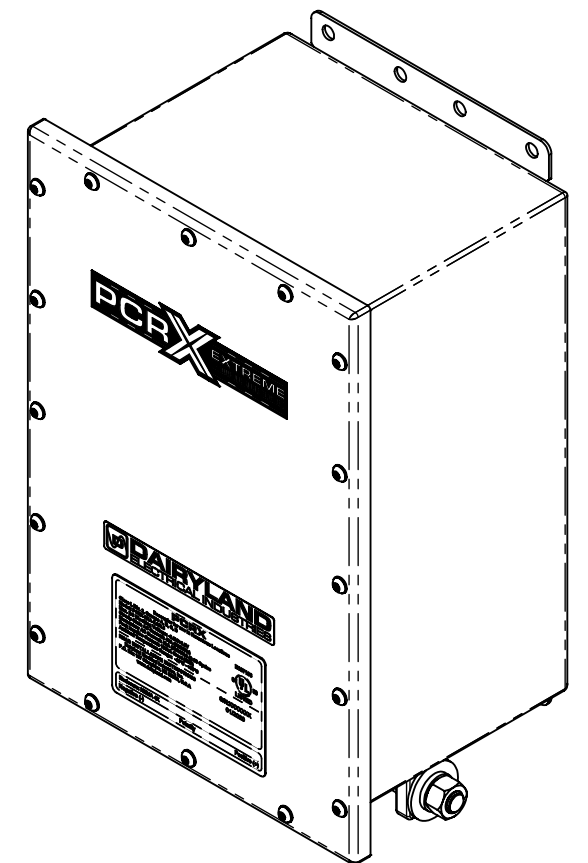
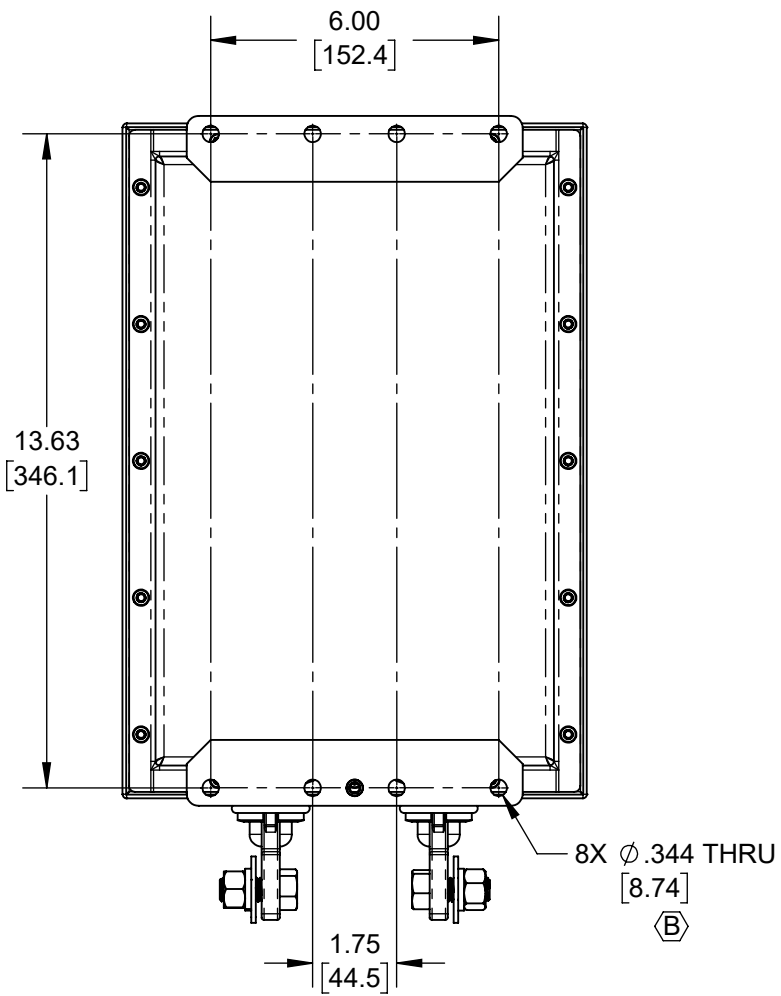
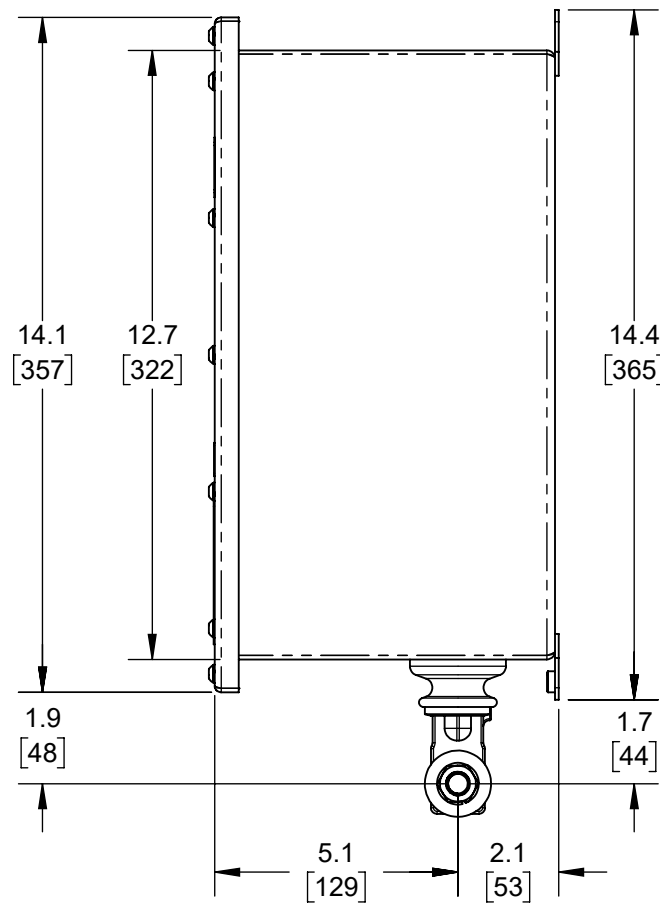
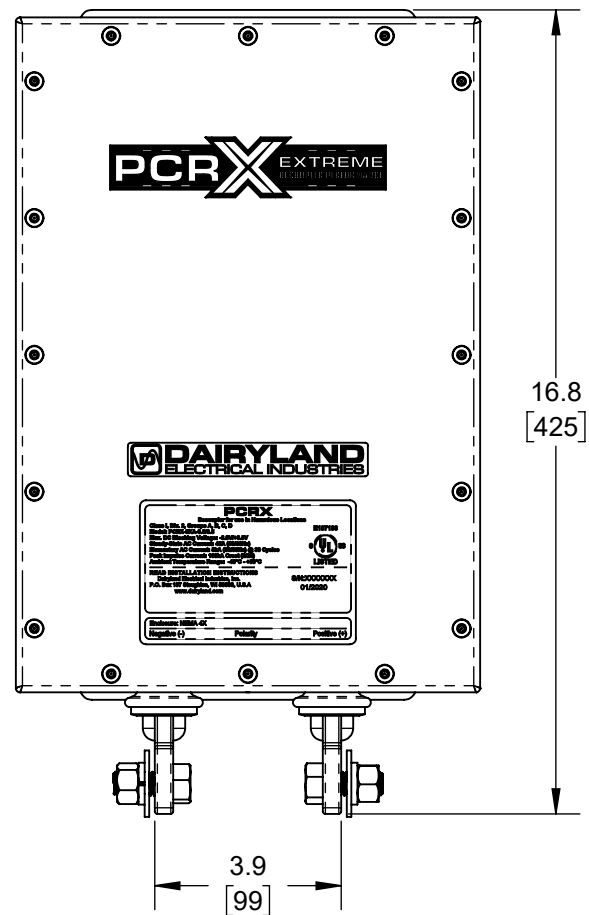
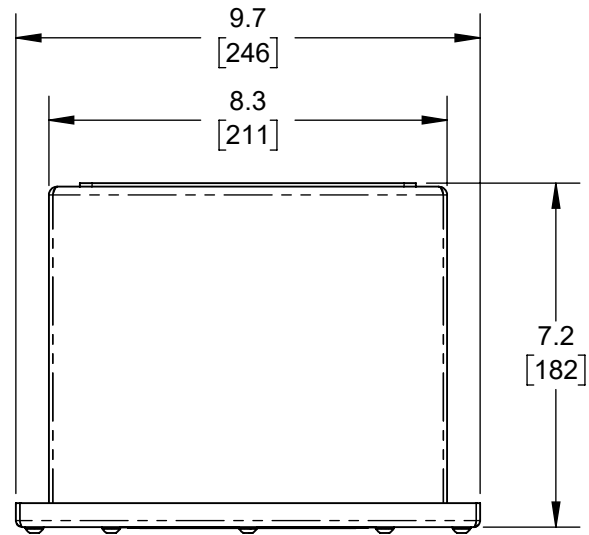

ISOMETRIC VIEW

ASME Y14.5M 2018 APPLIES UNLESS OTHERWISE SPECIFIED DIMENSIONS ARE IN INCHES. COMPUTER-GENERATED DRAWING DO NOT EDIT MANUALLY.	MATERIAL: SEE BOM	DRAWN: MAD	DATE DRAWN: 3/27/2020	 P.O. BOX 187 STOUGHTON, WI 53589 608-877-9900 DAIRYLAND.COM
	FINISH: NA	DWG APPROVAL: RJH	DATE APPROVAL: 03/31/2020	
.XXX = ±.005" .XX = ±.01" .X = ±.03" ANGLES = ±1°	THE INFORMATION CONTAINED IN THIS DRAWING IS THE SOLE PROPERTY OF DAIRYLAND ELECTRICAL INDUSTRIES, INC. ANY REPRODUCTION IN PART OR WHOLE, WITHOUT THE WRITTEN PERMISSION OF DAIRYLAND ELECTRICAL INDUSTRIES, INC. IS PROHIBITED.		SHEET: 1 OF 1 DWG SIZE: B SCALE: 1:4	REV: 1 PART #: 200023