

INSTRUCTIONS

GRADIENT CONTROL MAT (GCM)



DAIRYLAND
ELECTRICAL INDUSTRIES

ALWAYS RUGGED. ALWAYS RELIABLE.



INTRODUCTION

Most gradient control mats are designed and installed around above ground pipeline appurtenances to limit power frequency voltages. The Dairyland gradient control mat is designed to also limit potentially hazardous voltages due to lightning, a much more difficult task. Step potentials are inherently controlled by the design of the mat (grid wire size, grid spacing, etc.), but the touch potential that a worker may be subject to is determined both by the mat design and the installation; therefore, these installation guidelines must be followed to provide maximum protection from lightning-caused voltages.

The reason for this is that conductors inherently have inductance and when a very fast rising current, such as from lightning, flows through the conductor from the pipeline to the mat a significant voltage per unit of conductor length is developed. This voltage drop adds directly to the touch potential for a worker standing on the mat. Therefore, keep conductor connections between the mat and pipeline as short as possible – as described above.

WARNING

KEEP THE CONDUCTORS SHORT!

The most significant installation factor is to keep the conductor that connects the mat to the pipeline as short as possible, preferably 8" (200 mm) or less, whether the mat is direct connected to the pipeline or connected through a Dairyland solid-state decoupler.

Materials Required for Installation

1. Gradient Control Mats (4' x 8'), GCM4-8
2. If more than one mat is required, then weld the mats together using the Dairyland mold Mold-6X and an industry standard #25 cartridge that can be purchased from any industry source. Do not join mats with compression type or bolted type connections - thermit weld only.
3. Magnesium anodes per Table 2, Section 2.1 and 2.2 in the attached Correng Report, and backfill, if not provided with the anode.
4. To thermit weld a #6 AWG anode lead or the #6 decoupler leads to the mat (if the mat is decoupled) use Mold-6X and a standard #25 CP cartridge/shot. To thermit weld a #10 or #12 AWG lead, use Mold-6X with a #15 CP cartridge/shot. Do not attach leads with compression type or bolted type connections - thermit weld only.
5. Wire cutters for 0.135" diameter steel wire (If necessary to cut out sections of the mat to fit around pipelines.)
6. A Dairyland Solid State Decoupler if used, typically Model SSD-A/B-C-D where A/B is the blocking voltage, C is the fault current rating at 30 cycles, and D is the lightning current rating in kA. The most common rating is the SSD-2/2-1.2-100 for gradient control mat decoupling. Reference the Dairyland technical literature for model SSD for ratings and outline drawings.
7. Decoupler conductors, 12" (300 mm) or 36" (900 mm) with factory installed terminals (one end only), order MTL-6-12 or MTL-6-36, with each kit containing two #6 AWG conductors. It is recommended that two conductors per decoupler terminal are used, but cut off all excess conductor to make connections as short as possible.
8. Mounting of decoupler:
 - By banding: Banding material to be selected/purchased by user
 - By mounting to 8 mm pin brazed studs. Equipment/studs/ceramic ferrules by user. Requires one Hex Coupling Nut from Dairyland, model #HCN-M8
 - By securing to a post adjacent to the pipeline: User furnished.

The first two mounting methods are illustrated in sheets 2 and 3 of the attached drawing 100103.
9. Sealant for all thermit welds: Denso LT tape (Available from Dairyland in 2"x33'rolls)
10. Crushed limestone to cover mat 6" (Use clean washed stone only if limestone is not available.)



INSTALLATION INSTRUCTIONS

WARNING

During installation, the voltage on the structure may rise to an unsafe level (i.e., due to induced AC, AC fault or lightning on the structure). Sparking and current flow may occur when making or breaking connections between the structure and the gradient control mat. Assure that this does not occur in hazardous locations where gases or vapors may be present. All necessary safety precautions must be taken by the user to avoid unsafe worker conditions, including arcing, in accordance with applicable industry and/or company-required practices. Dairyland provides suggested procedures for installing and operating this equipment (See the section on Worker Safety). But the user must be responsible for and approve the procedures to be used by its workers when installing the equipment because Dairyland cannot be familiar with each user's safety guidelines.

WARNING

Do not pin braze or weld in hazardous locations where explosive gases or vapors may be present.

Worker Safety

For worker safety during installation, it is recommended that the user obtain certain equipment; namely a pair of electrically insulated gloves, a shorting cable approximately 3 ft (0.91 m) long with insulated clamps on each end, and a multi-meter to measure AC voltage. (Of these items, Dairyland offers a suitable 3 ft long 1/0AWG shorting cable with insulated clamps, Model# BCL-1/0 for all decoupler ratings.) The following installation procedure assumes that these items are available. It is suggested that a grounding jumper be used as a safety precaution in the event the lead to the structure rises to an unsafe potential when it is disconnected during the installation process or if an electrical disturbance occurs while the decoupler is being installed. Be sure to remove the grounding jumper after the decoupler is completely installed. If the structure voltage is not at a safe touch potential (i.e., >15VAC to ground per NACE SP0177), then insulating gloves should be used.

Install mats and anodes as illustrated in the attached Correng Report. If a decoupler is used, refer to the attached decoupler drawing 100103.

1. Remove topsoil to a uniform depth of approximately 6" (150 mm) in an area that extends beyond the lateral mat dimensions. At the anode locations, excavate an additional 36" (900 mm) depth to the lateral dimensions of a horizontally oriented anode as depicted in the Correng Report. Apply backfill material around the anode (if the anode is not already bagged with backfill), and refill the hole with native soil, leaving the anode wire extended beyond the soil surface for later attachment to the mat.
2. Orient adjacent mats as follows: Flip the adjacent mat over so that the top grid wires on one mat are oriented 90° with respect to the top grid wires on the adjacent mat. This will enable the outer grid wires on adjacent mats to be placed directly next to each other, a requirement for the grid wires to fit properly in the thermit welding mold.
3. Locate the position of vertical pipe segments or other structures that will protrude through the mat, and using wire cutters, remove the unneeded portions of the mat so that the mat wires are no closer than 3" (75 mm) to the pipe at any point, which will avoid contact and abrasion to the pipe coating.
4. Place the mat segments in position around the structure, in the excavated area. When multiple mats are required for a given site, the adjoining mats should be thermit welded together approximately every 18" using the mold and weld charge recommended. Do not substitute or use any compression or bolted type connection.
- 5.) Weld the #6 AWG anode conductors to the mat as illustrated in the Correng Report using the mold and weld charge. For anodes with #10 or #12 AWG conductors, use Mold-6X with a #15 CP cartridge. Do not substitute or use any compression or bolted type connection.
6. If the mat is to connect to the pipe through a decoupler, mount the decoupler as close to the mat as feasible, taking into account that the mat is to be covered with 6" of crushed limestone. The mounting method for the decoupler should have been pre-determined by the user and may consist of banding to the pipe wall, mounting by using 8 mm studs pin brazed to the pipe, or by mounting to a post adjacent to the pipe that is to be connected to the mat. All mounting is to be user furnished, except, if 8 mm studs are pin brazed to the pipe, a hex coupling nut kit is required from Dairyland (#HCN-M8) to make the connection from one decoupler terminal directly to the pipe wall. See the attached figures for various decoupler mounting methods.



7. Make conductor connections from the appropriate decoupler terminal to the closest section of mat with the short-est lead that will still allow welding of the conductor to the mat using the Mold-6X for #6 AWG. Two #6 conductor connections are recommended from each decoupler terminal as this also helps to minimize lead inductance, with one conductor set to the pipe and the other set to the mat, each preferably less than 8" (200 mm) long. Of the two Dairy-land decoupler conductor lengths available, the 36" (900 mm) long conductors are never recommended when limiting touch potentials due to lightning is of concern, but this length is acceptable for power frequency voltages. When connections are made to adjacent mats as illustrated in Figure 1 (bottom view) of the Correng Report it is desirable to mount the decoupler so one conductor goes to each mat with the shortest possible conductor length.
8. After all welding is complete (i.e., all mat to mat and lead to mat welds), seal around and beyond the end of each weld with two or more layers of Denso LT petrolatum tape or other user approved sealant. When the Denso tape is used, a 4" long piece of the 2" wide tape is required to seal each weld.
9. Cover the entire gradient control mat with 6" of crushed limestone (alternatively, use clean washed stone, but only if crushed limestone is not available). Extend the covering at least several feet beyond the outer edges of the mat on all sides.

Note: This drawing to be used in combination with Gradient Control Mat installation instructions

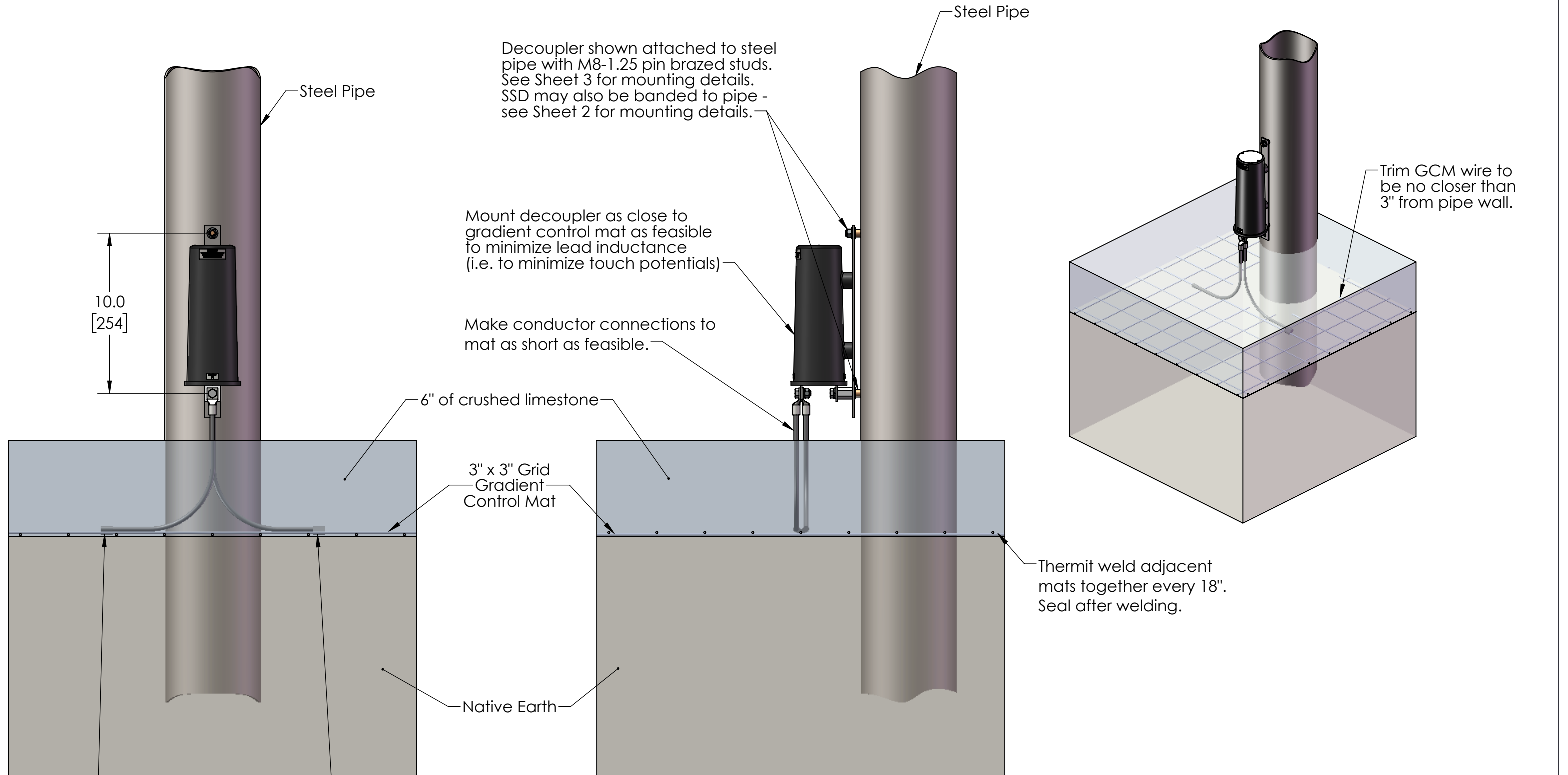

Thermit weld #6 Awg. decoupler conductors and anode conductors to mat. Seal after welding.

ANSI Y14.5M 1994 APPLIES
 UNLESS NOTED UNITS: INCHES
 3-PLACE: ±.005
 2-PLACE: ±.015
 1-PLACE / FRAC: ±.03
 ANGULAR: ±1



DAIRYLAND ELECTRICAL INDUSTRIES, INC.
 P.O. BOX 187
 STOUGHTON, WI 53589
 608-877-9900
 DAIRYLAND.COM

DESCRIPTION Decoupling of Gradient Control Mat: Typical Installation				
DOCUMENT #	REV	DATE DRAWN	DWG SIZE	DATE APPROVAL
100103	A	2017-02-20	B	2017-02-24
SCALE 1:6	DRAWN: JPW	SHEET: 1 OF 3	DWG APPROVAL: JWV	

Note: This drawing to be used in combination with Gradient Control Mat installation instructions

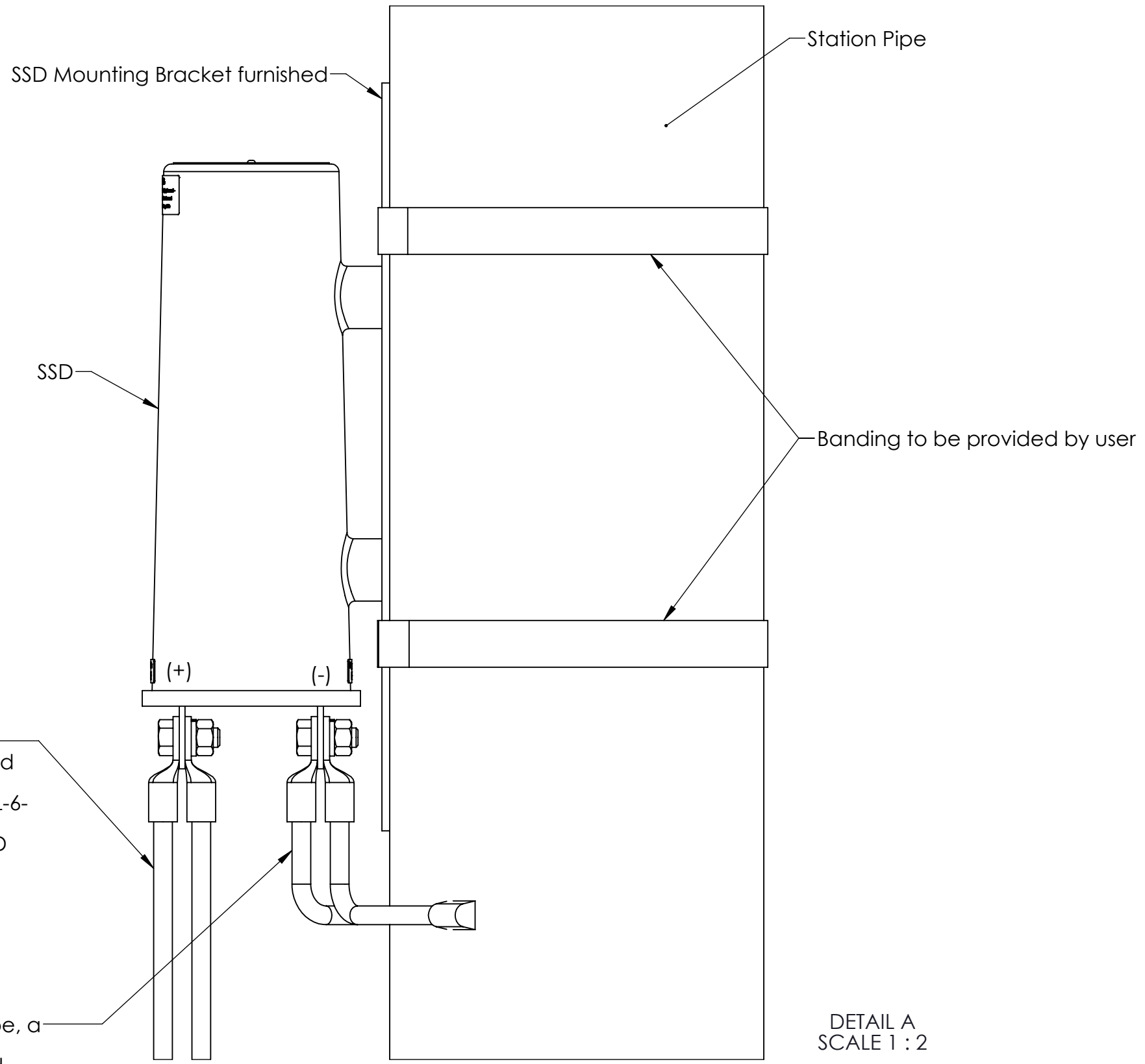
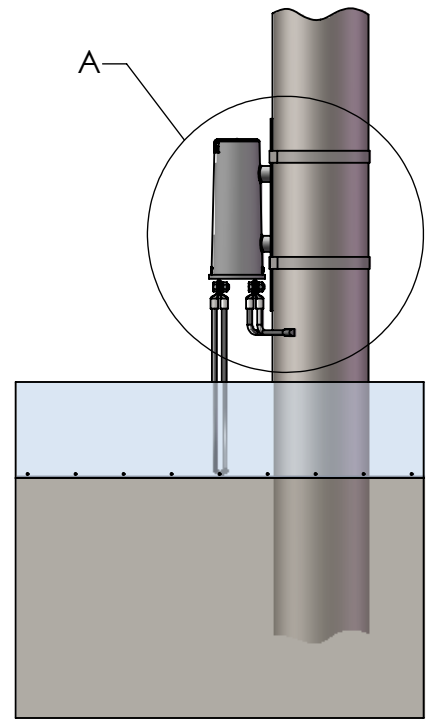

#6 AWG conductors with terminals attached on one end plus nuts, bolts, and washers available from Dairyland. Specify #MTL-6-12 for 12" (300mm) or MTL-6-36 for 36" (900mm) for a set of two conductors. Two conductors to each SSD terminal are recommended. Other conductor ends are unfinished.

For conductor connections to a steel pipe, a thermit weld is recommended. Make conductor lengths between SSD bus and pipe as short as possible to minimize inductive voltage drop due to lightning and switching transients.

DETAIL A
SCALE 1 : 2

ANSI Y14.5M 1994 APPLIES
UNLESS NOTED
UNITS: INCHES
3-PLACE: ±.005
2-PLACE: ±.015
1-PLACE / FRAC: ±.03
ANGULAR: ±1



**DAIRYLAND
ELECTRICAL
INDUSTRIES, INC.**
P.O. BOX 187
STOUGHTON,
WI 53589
608-877-9900
DAIRYLAND.COM

DESCRIPTION		Decoupling of Gradient Control Mat: Banding SSD to Pipe			
DOCUMENT #	REV	DATE DRAWN	DWG SIZE	DATE APPROVAL	
100103	A	2017-02-20	B	2017-02-24	
SCALE 1:12	DRAWN: JPW	SHEET: 2 OF 3	DWG APPROVAL: JWV		

Note: This drawing to be used in combination with Gradient Control Mat installation instructions

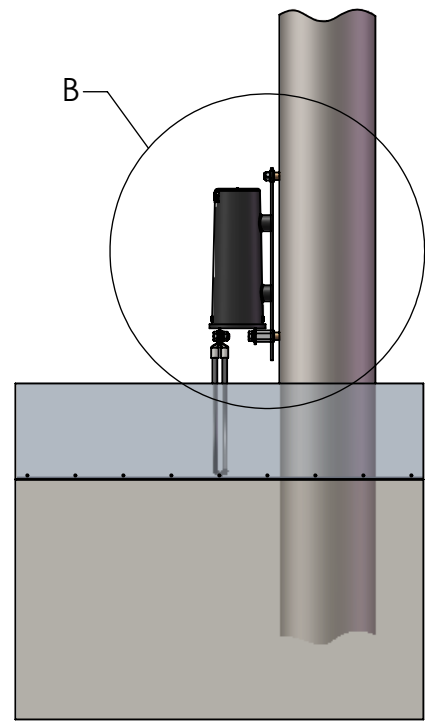

This installation method requires pin brazing equipment and M8 -1.25 threaded studs furnished by others. Install studs to spacing shown +/- 0.10" or +/- 2.5mm. Contact Dairyland for further information

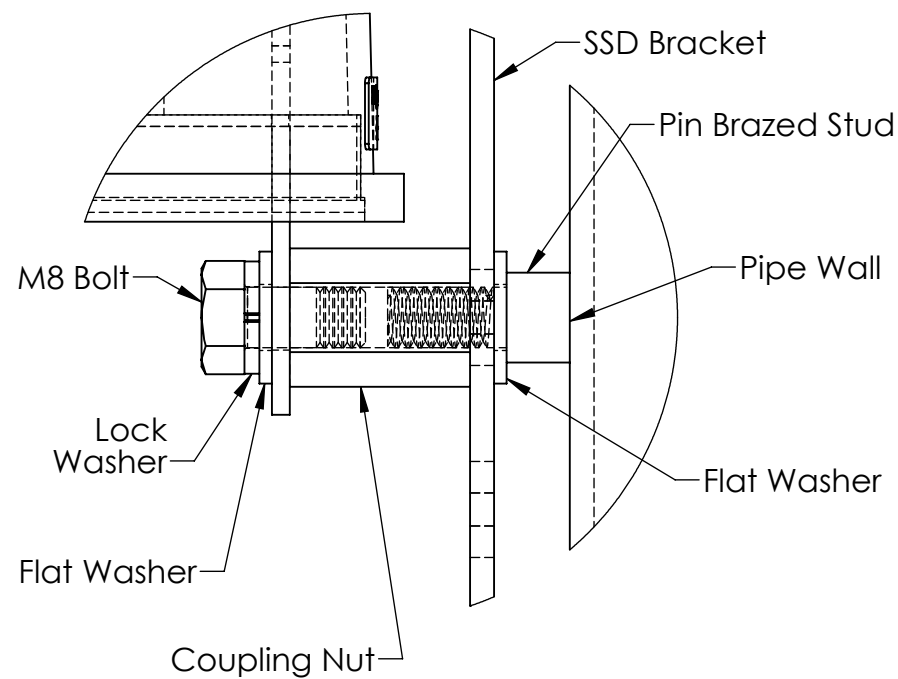

DETAIL C
SCALE 1 : 1

To connect NEGATIVE terminal to pipe via the pin brazed stud, specify #HCN-M8 to obtain the Hex Coupling Nut plus M8 Bolt and washers required. Use with SSD model: SSD-2/2-1.2-75

Hex coupling nut is first tightened onto pin brazed stud, then M8 bolt (with washers) is tightened into the coupling nut.

#6 Awg conductors with terminals attached on one end plus nuts, bolts, and washers available from Dairyland. Two conductors are recommended to the SSD terminal. Other conductor ends are unfinished.

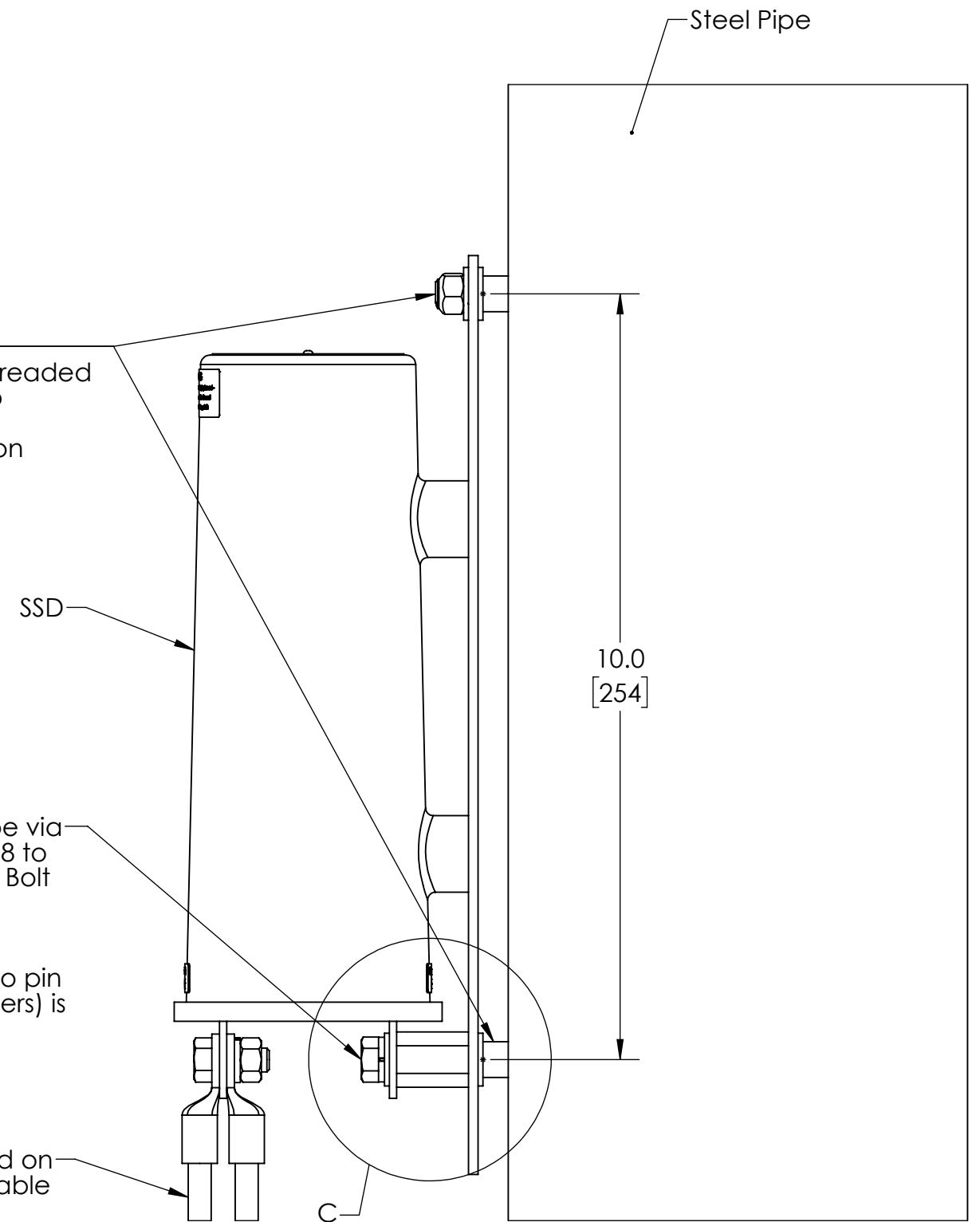

DETAIL B
SCALE 1 : 2

ANSI Y14.5M 1994 APPLIES
UNLESS NOTED UNITS: INCHES
3-PLACE: ±.005
2-PLACE: ±.015
1-PLACE / FRAC: ±.03
ANGULAR: ±1



DAIRYLAND ELECTRICAL INDUSTRIES, INC.
P.O. BOX 187
STOUGHTON, WI 53589
608-877-9900
DAIRYLAND.COM

DESCRIPTION		Decoupling of Gradient Control Mat: Pin Brazed Stud Connection to Pipe			
DOCUMENT #	REV	DATE DRAWN	DWG SIZE	DATE APPROVAL	
100103	A	2017-02-20	B	2017-02-24	
SCALE 1:12	DRAWN: JPW	SHEET: 3 OF 3	DWG APPROVAL: JWV		



GUIDELINES FOR CATHODIC PROTECTION OF GALVANIZED STEEL GRADIENT CONTROL MATS

1.0 APPLICABILITY

- 1.1 These guidelines apply to cathodic protection of galvanized steel gradient control mats installed at pipeline appurtenances to reduce electrical step and touch potentials in areas where persons could come into contact with a pipeline appurtenance subject to hazardous potentials.
- 1.2 These guidelines do not apply when the gradient mat is connected to other grounding systems, either directly or indirectly through the pipeline appurtenance. These applications require consultation with a cathodic protection specialist.
- 1.3 If the pipeline is not cathodically protected, the galvanized steel mat should be connected only via a decoupling device, or provision should be made to protect both the pipe and the mat in consultation with a cathodic protection specialist.

2.0 ANODES

- 2.1 The magnesium anodes used to protect the mats should be either high potential packaged magnesium anodes (Alloy M1C) or H1-Alloy (Standard) packaged magnesium anodes, as indicated in Table 1.

Table 1. Magnesium Anode Data

Anode Type	Alloy (ASTM B843-93)	Weight (Lbs.)	Standard Package Dimensions
17S4	H-1 Alloy Grade A	17	6.5" x 19"
17D4	M1C (High Potential)	17	6.5" x 19"
32S5	H-1 Alloy Grade A	32	8" x 30"
32D5	M1C (High Potential)	32	8" x 30"

- 2.2 The packaged anodes should be provided with 10 ft. of AWG 6/7 RWU 90 cable. The backfill should be a mix of 75% hydrated gypsum, 15% bentonite, and 5% sodium sulphate.



CP of Galvanized Steel Gradient Control Mats

2.3 The type and quantity of the packaged anodes should be in accordance with Table 2. Contact DEI if the size of the mat exceeds 16' x 16'.

Table 2. Required Type and Number of Magnesium Anodes

Mat Size	Soil Resistivity (Ω -cm) ^[1]	Anode Type	Required No. of Anodes	Calculated Anode Service Life		Layout
				Decoupled GCM	Directly Connected GCM ^[2]	
4' x 8'	Low (1000 to 2000)	32S5	1	>20 years	>18 years	Figure 3
	Moderate (Over 2000)	17S4	1	>20 years	>20 years	Figure 3
8' x 8'	Low (1000 to 2000)	32S5	1	>20 years	>17 years	Figure 1
	Moderate (Over 2000)	17D4	1	>20 years	>20 years	Figure 1
8' x 16'	Low (1000 to 2000)	17S4	2	>20 years	>19 years	Figure 4
	Moderate (Over 2000)	32D5	1	>20 years	>20 years	Figure 3
12' x 16'	Low (1000 to 2000)	32S5	2	>20 years	>20 years	Figure 4
	Moderate (Over 2000)	32D5	2	>20 years	>20 years	Figure 4
16' x 16'	Low (1000 to 2000)	32S5	2	>20 years	>19 years	Figure 2
	Moderate (Over 2000)	32D5	2	>20 years	>20 years	Figure 2

^[1] The cathodic protection system was designed to provide an anode life in excess of 20 years in soil resistivities as low as 1000 Ω -cm and to provide the required protection current at soil resistivities up to 15,000 Ω -cm. Soils with resistivities higher than 15,000 Ω -cm are not considered corrosive.

^[2] If the gradient control mat is directly connected to a pipe appurtenance, then the polarized potential of the protected structure is expected to drop from -1100mV_{CSE} to -850 mV_{CSE} and the service life of the anode would be reduced by 28% for high potential anodes and by 36% for H1-Alloy anodes.



3.0 ANODE INSTALLATION

- 3.1 The anodes should be installed horizontally approximately 3 ft. below the mat, as indicated in Figures 1 to 4.
- 3.2 The anode wire should be run to a close mat wire. The radius of bends should be at least 8".
- 3.3 The #6 AWG anode wire connections to the 0.135" diameter galvanized steel wire of the gradient control mat and the mechanical/electrical bonding of the galvanized steel wires in adjacent gradient control mats should be done by thermit welding. Custom molds and the weld metal for each case are available from DEI (Dairyland Electrical Industries, Inc.) All thermit welded connections should be sealed with two or more layers of Denso LT tape.

3.0 ANODE INSTALLATION CONT'D

3.3 Cont'd

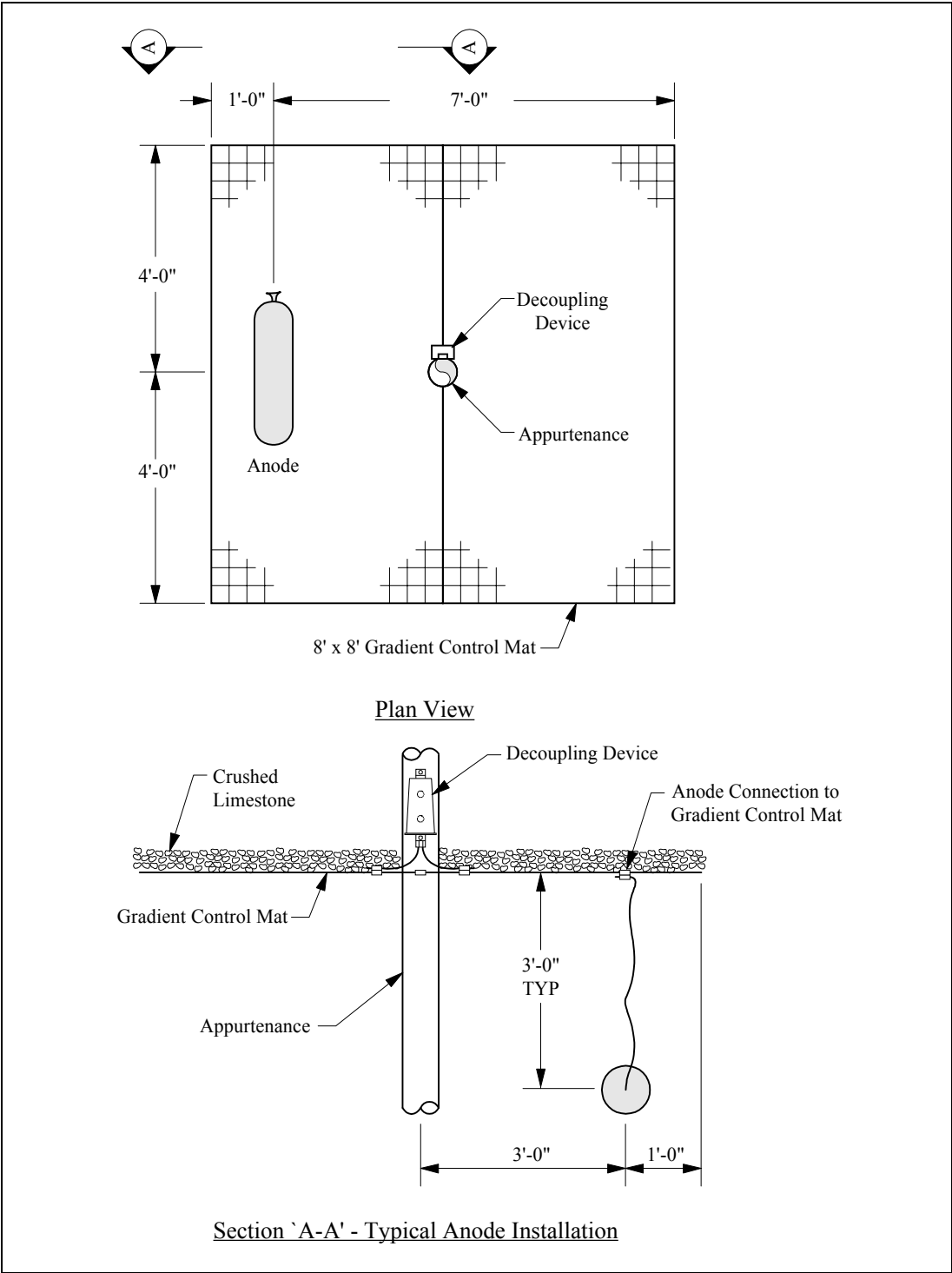

FIGURE 1 • Square Gradient Control Mat with One Anode

3.0 ANODE INSTALLATION CONT'D

3.3 Cont'd

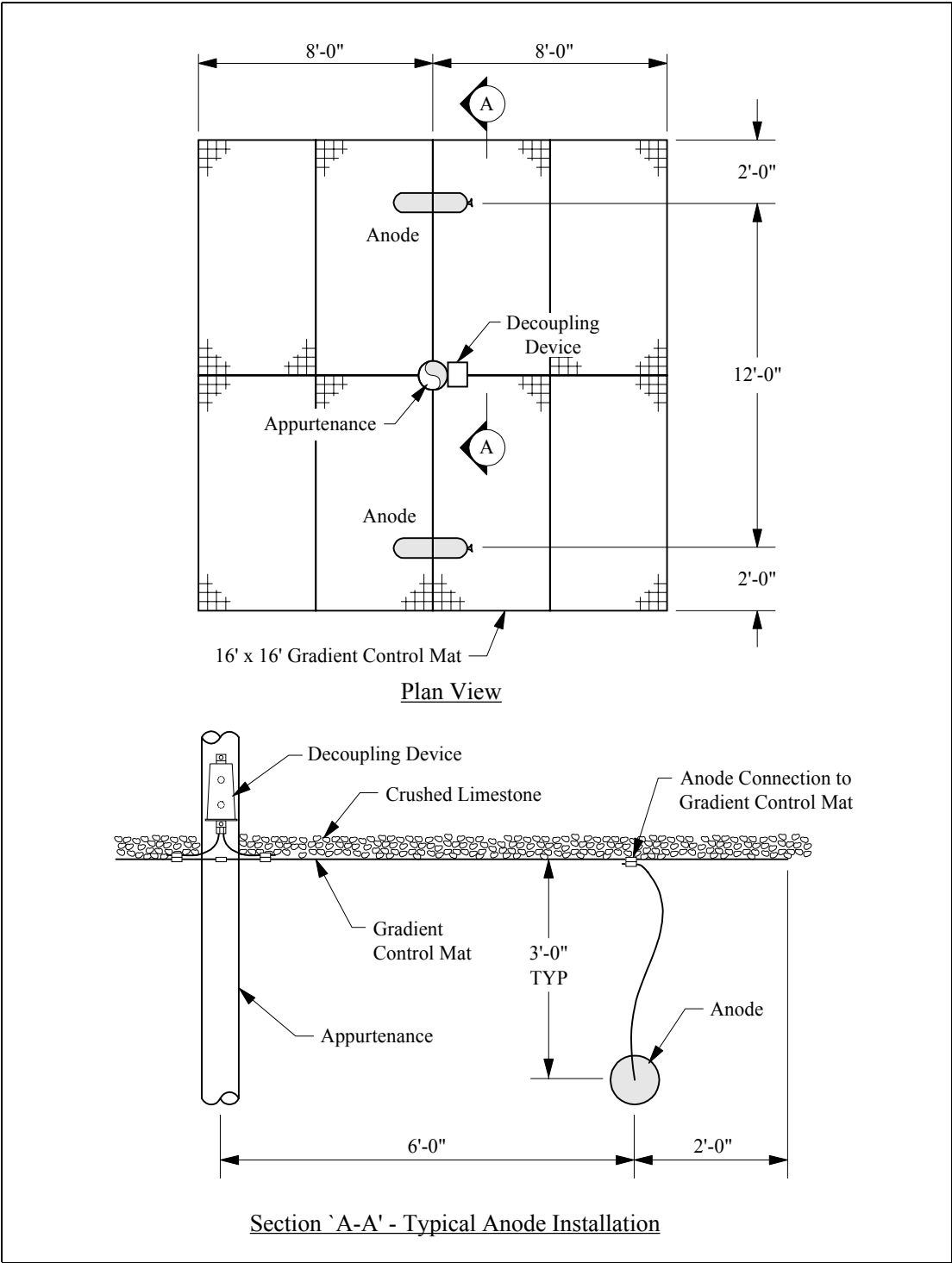

FIGURE 2 • Square Gradient Control Mat with Two Anodes

3.0 ANODE INSTALLATION CONT'D

3.3 Cont'd

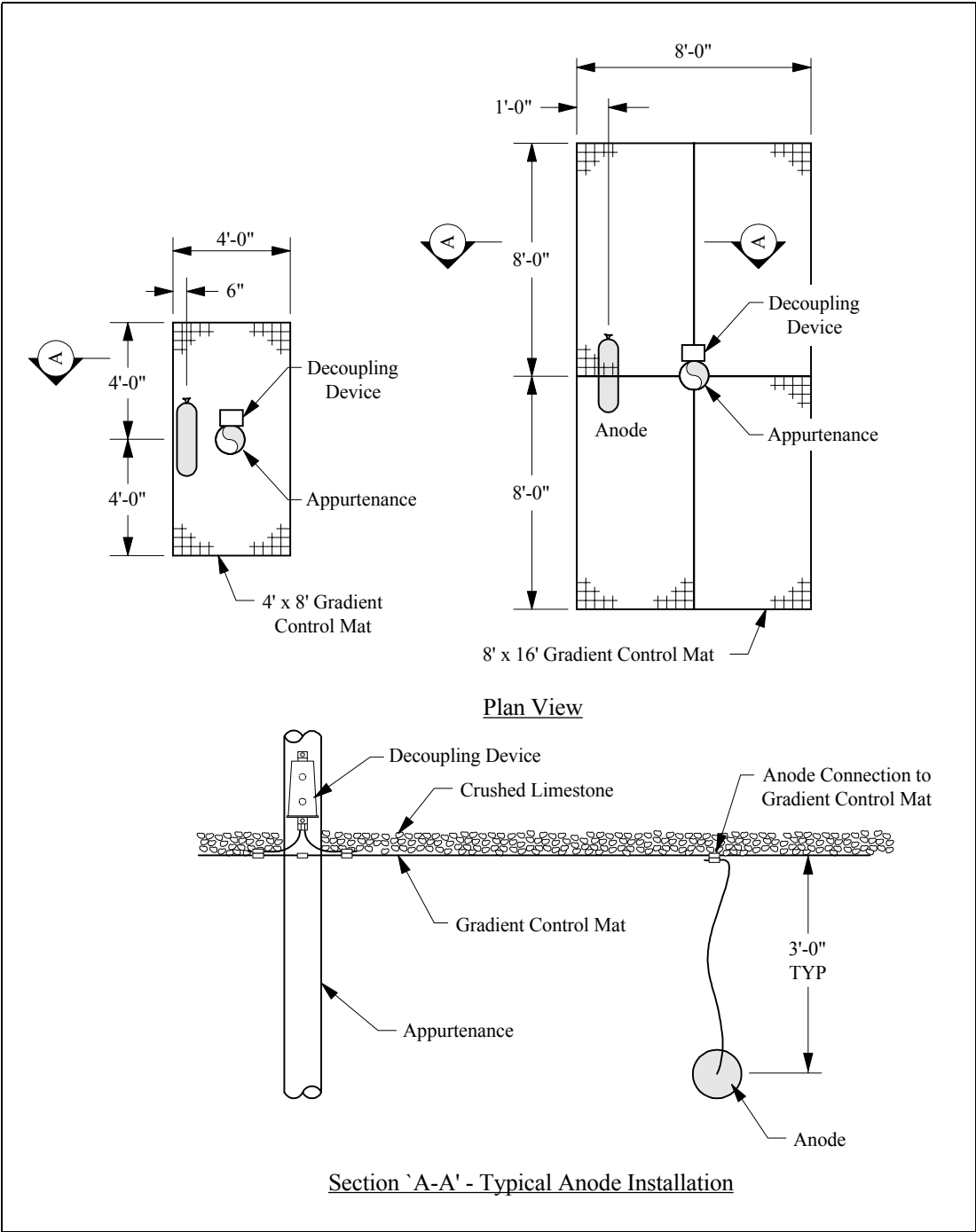

FIGURE 3 • Rectangular Gradient Control Mat with One Anode

3.0 ANODE INSTALLATION CONT'D

3.3 Cont'd

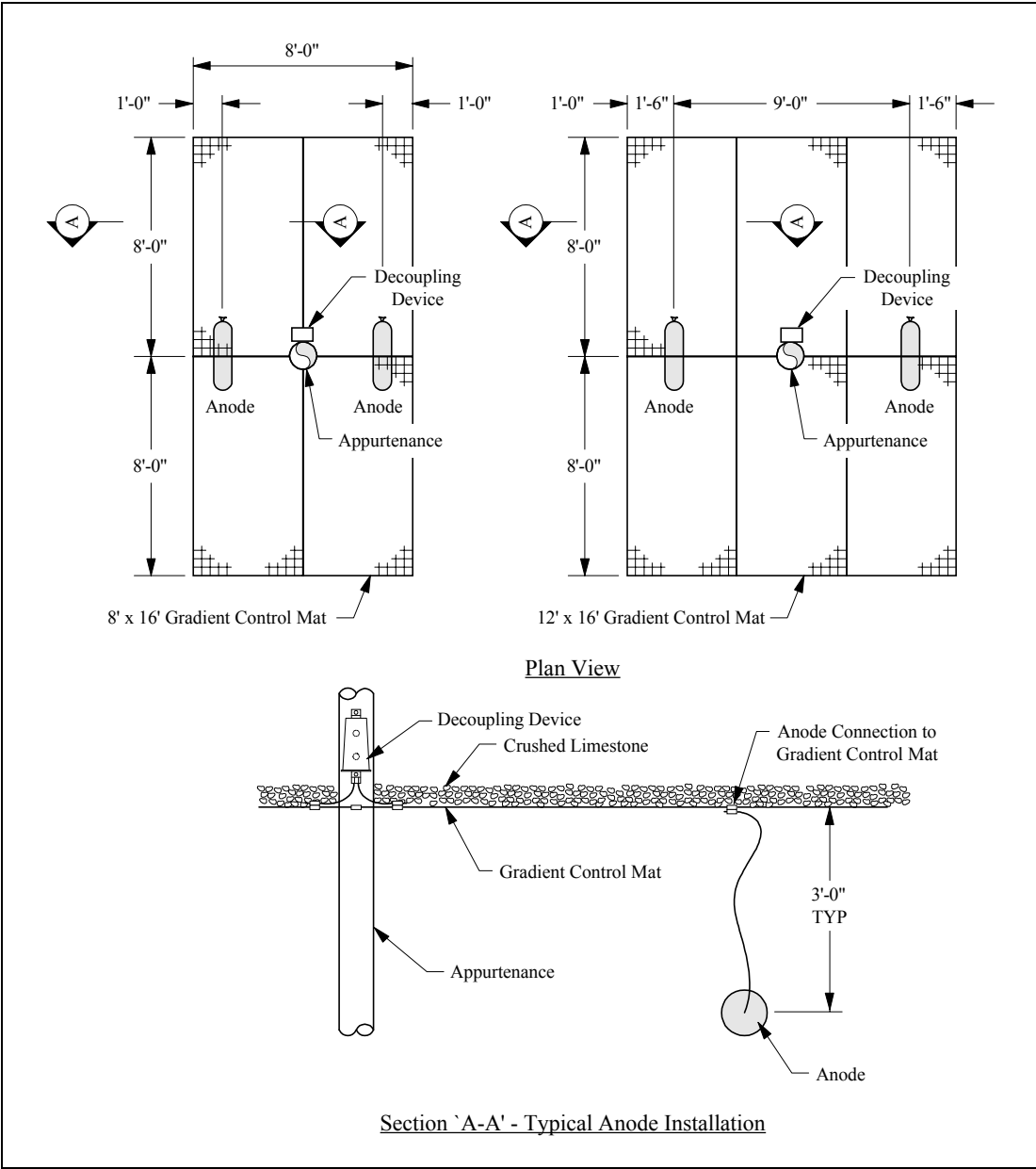

FIGURE 4 • Rectangular Gradient Control Mat with Two Anodes



4.0 ADDITIONAL RECOMMENDATIONS

- 4.1 It is recommended to use crushed limestone as the high resistivity layer to be installed on top of the safety mat, in order to minimize the attack of acid rain on the galvanized steel.