

BILL-OF-MATERIAL KIT #: 3451, DOCUMENT NAME: MTG-OVP2

LINE NO.	DOCUMENT NUMBER	DESCRIPTION	QTY.
1	-	OVP2	1
2	3453	Washer EPDM 1.00" Dia x 1/32" thick	1
3	2495	Bracket OVP2 Mounting	1
4	2617	Screw PH FH 10-32x1/2"	1

REVISIONS			
REV.	DESCRIPTION	DATE	APPROVED
B	CORRECTED ORIENTATION OF TERMINALS	2015-04-13	HNT

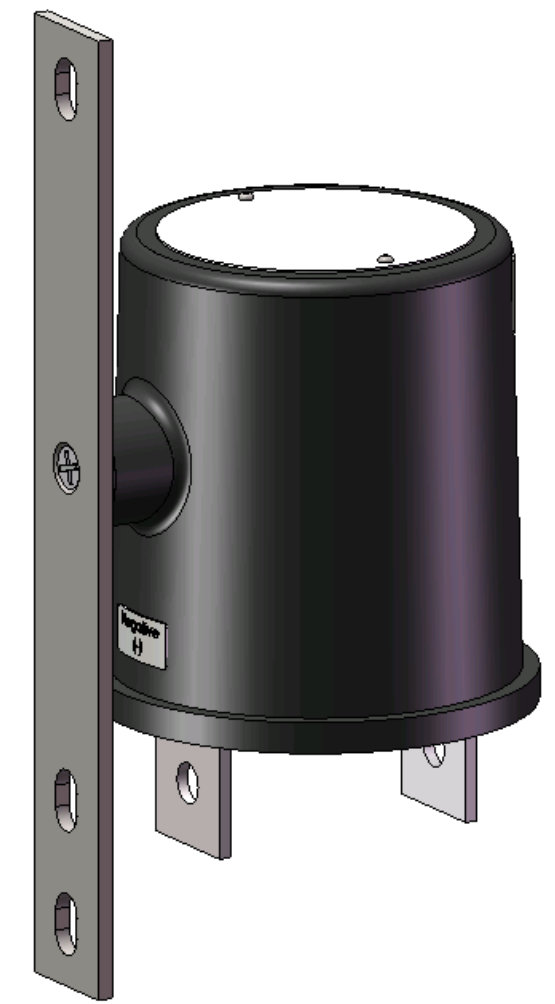
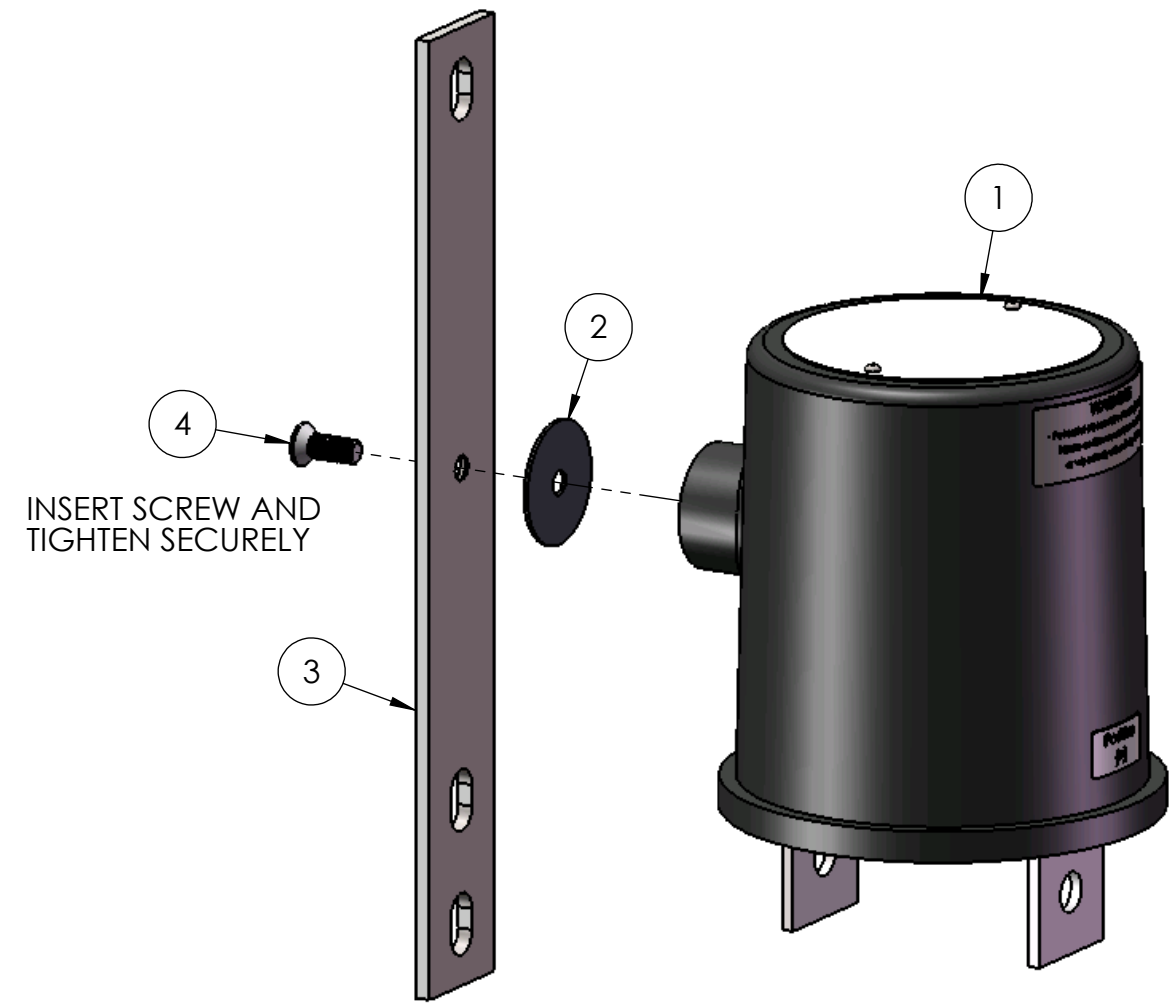

ANSI Y14.5M 1994 APPLIES  
 UNLESS NOTED  
 UNITS: INCHES  
 3-PLACE: ±.005  
 2-PLACE: ±.015  
 1-PLACE / FRAC: ±.03  
 ANGULAR: ±1



DAIRYLAND  
 ELECTRICAL  
 INDUSTRIES, INC.  
 P.O. BOX 187  
 STOUGHTON,  
 WI 53589  
 608-877-9900  
 DAIRYLAND.COM

DESCRIPTION MTG-OVP2 INSTALLATION				
DOCUMENT # 100054	REV B	DATE DRAWN 2014-01-29	DWG SIZE B	DATE APPROVAL 2014-01-30
SCALE 2:3	DRAWN: JPW	SHEET: 1 OF 1	DWG APPROVAL: KJS	