



APPLICATION GUIDE

# UTILITY GROUNDING



## PROBLEM

Pipeline facilities and tank farms, among other similar cathodically protected sites, need to have manageable CP current requirements to achieve acceptable industry CP potentials for compliance. Corrosion staff expect to have reasonable current demand to shift the potentials of their protected structures, however the facility bond to the power company grounding system can make this difficult. An unknown, and large, amount of buried metallic area exists on the power utility system, in the form of copper ground rods and other grounding electrodes, as well as a connection to all of their other customers' grounding systems. This excessive bare area becomes part of the cathodically protected structure from a current-requirement perspective, overwhelming the design goals, and allowing unintended interaction to occur. High rectifier output to meet the current demand also can cause excessive voltage gradients in the soil that result in interference with other nearby structures, including both owned and foreign systems, affecting CP potentials and possibly causing corrosion. See Figure 1.

DC current flow involving the utility system may seem to be of no real concern to the power utility, since current pickup is generally associated with protection, while current discharge from a structure relates to corrosion taking place. However, excessive current pickup at grounding electrodes on a utility system may cause calcareous deposits on the electrode, coating it in a non-conductive build-up that increases the resistance of the primary neutral to earth.

The common tie between cathodically protected facilities and power utility grounding systems is the bond that exists at the electrical service. Specifically, the primary-to-secondary neutral bonding system facilitates cathodic protection current flow between the two facilities. However, this bond exists to meet safety requirements and cannot be simply separated for convenience.

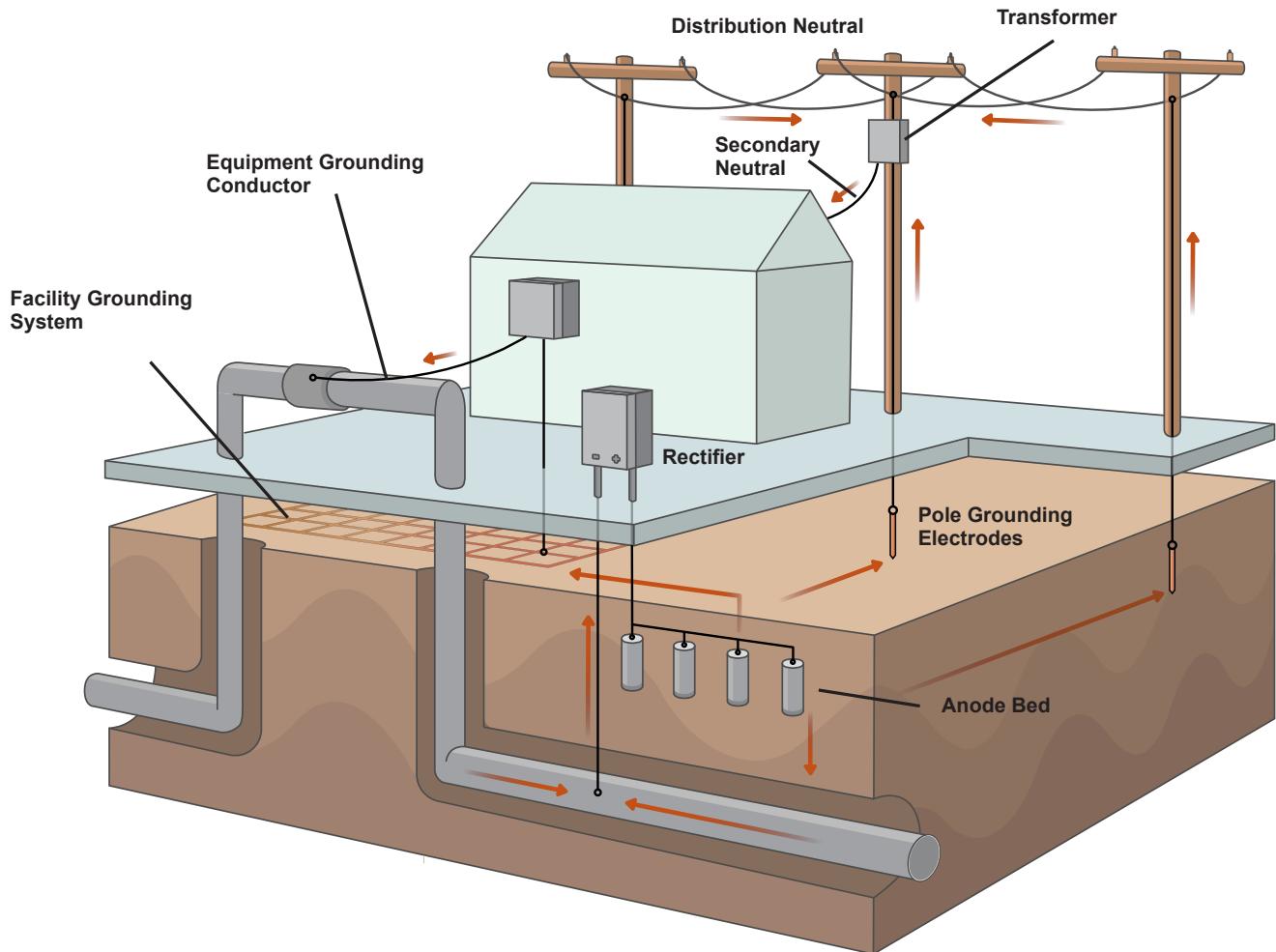

Figure 1: Facility cathodic protection interacts with power utility grounded neutral system

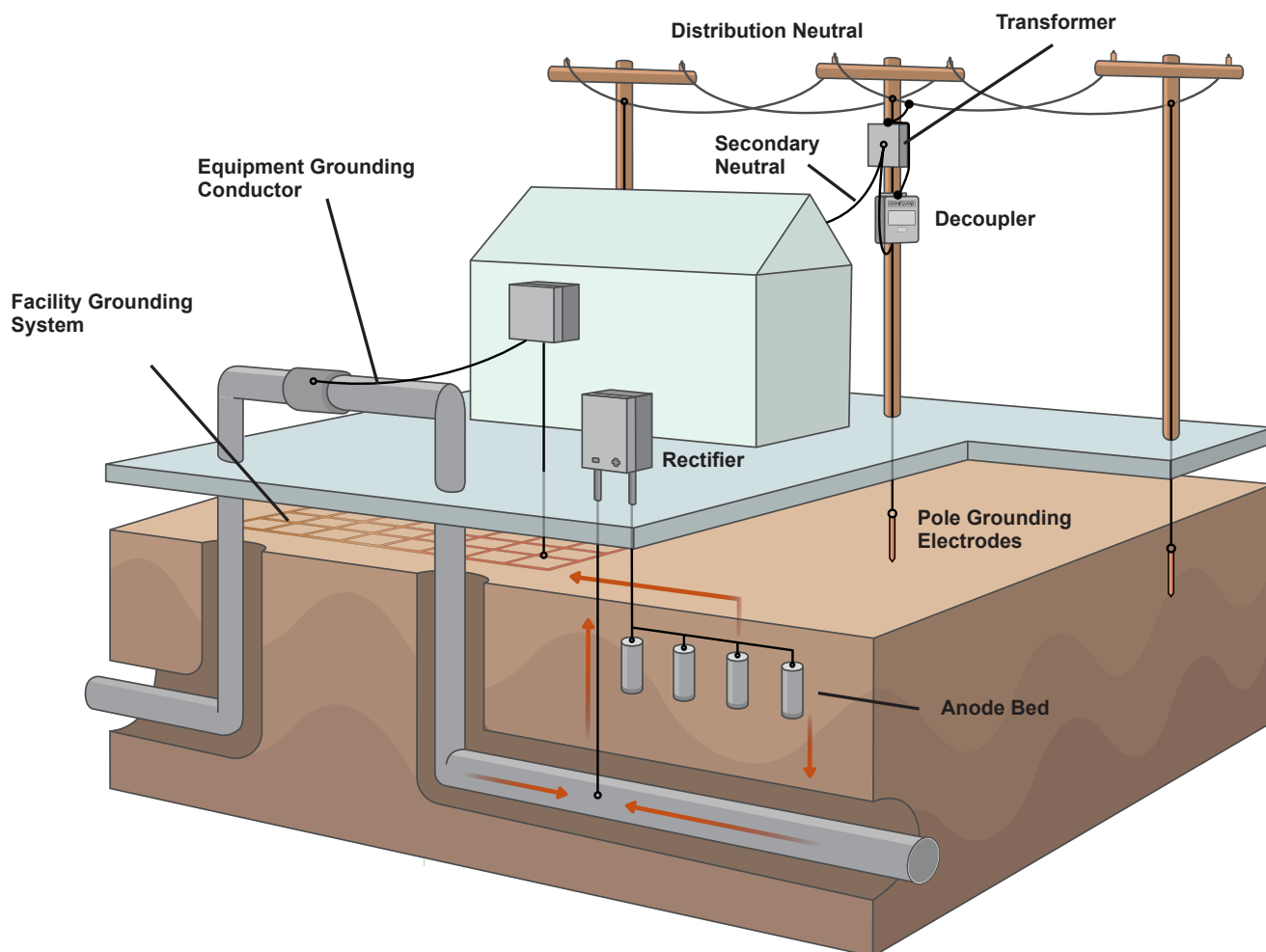

Figure 2: Decoupler dc isolates power utility grounded neutral system

## SOLUTION

The utility (primary) and customer (secondary) systems are bonded together by default to facilitate the safe operation, should either system attempt to rise in voltage, such as during an ac fault or lightning event. Bonding assures that both systems remain close in voltage. Permanent separation of the two systems is not an option, due to safety concerns. However, there exists one acceptable method to address cathodic protection issues along with safety bonding. Dairyland decouplers are solid-state devices which block direct current from active or passive sources, while simultaneously appearing continuous for ac power frequency signals. A suitably rated decoupler can be installed as the bond between primary and secondary neutrals (and therefore between the two grounding systems). This results in a great reduction of CP current required, limits interference with other structures, and allows CP potentials to achieve industry compliance. See Figure 2, where a decoupler has been installed at the transformer, resulting in CP current flow only to the intended facility.

Dairyland decouplers, such as the model PCR family, have been used extensively in the cathodic protection and power utility industries for decades. Primary-to-secondary bonding solutions involving decouplers are standardized to allow uniform application of devices across the utility system, whether served by single or three-phase, pole or pad mount transformers.

This application guide provides specific information on decoupler installation to solve facility CP problems, including connections, possible bypasses, practices, and codes.



## POWER UTILITY BONDING AT TRANSFORMERS

The typical utility single or three-phase distribution circuit has a multiple grounded neutral system, connecting the neutral at various points to grounding electrodes, and referencing the neutral to the secondary neutral and/or grounding system at the transformer. A common single-phase transformer arrangement at a customer service is depicted in Figure 3.

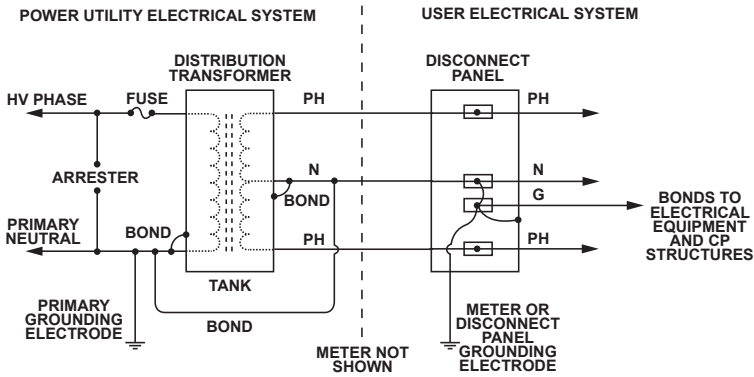

Figure 3: Typical electrical service involving cathodic protection conductor

Often, the secondary customer's CP system is intentionally, or inadvertently, connected to all facility structures and grounding system. The site grounding conductors and bonds reference the facility to the secondary neutral, which is connected at the transformer secondary neutral bushing to the tank, which in turn ties to the utility's primary neutral, and its grounding system. These connections result in CP current pickup on the utility grounding system and is returned via these bonds at the transformer and service to the cathodically protected facility. Figure 4 shows this current flow, before remediation.

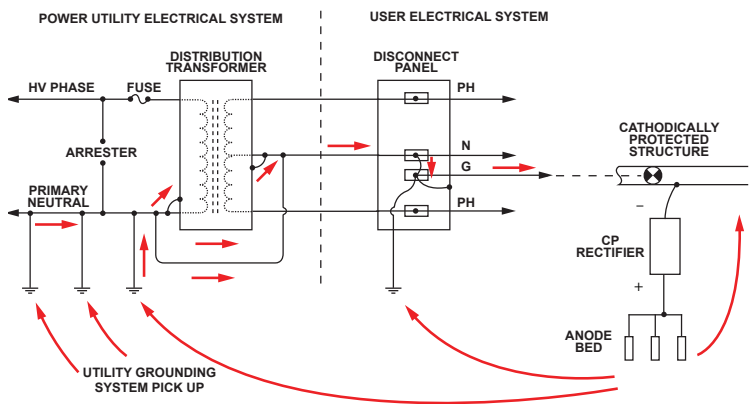

Figure 4: Current flow on typical electrical service involving cathodic protection

Addition of a decoupler at the transformer, between the primary neutral and secondary neutral, and clearing all bypasses, results in the facility CP system protecting only that site, as shown in Figure 5. Note that one of the bypass points is the tank grounding strap at the secondary neutral bushing. This is removed as the decoupler is installed. The tank remains bonded, as before, to the primary neutral and grounding electrode. The decoupler, as an ac-continuous device, keeps the secondary neutral solidly referenced to the primary neutral for safety, but blocks dc.

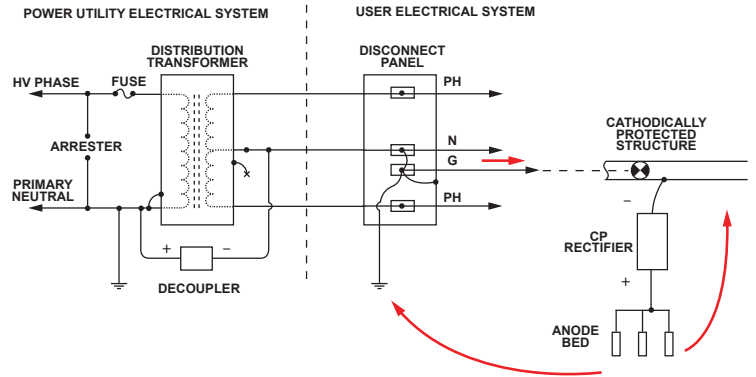

Figure 5: Decoupling effect upon typical electrical service involving cathodic protection

Three-phase service encounters the same basic issue due to bonding of primary and secondary neutrals. For pole type (conventional) transformers arranged for three-phase service, all connections are external to the tank, so decoupling between primary and secondary is exactly the same as for single-phase. However, pad-mounted three-phase service can involve an interesting twist. In Figure 6, a wye-wye transformer is shown, with an internal link between the primary and secondary neutrals. Besides the wired bonds and tank grounding straps that exist between primary and secondary neutrals, an internal link bonding the two systems results in a third connection, all of which pass cathodic protection current. Note that some pad-mounted transformers do not have this internal connection, while others that do may not provide access to the link.

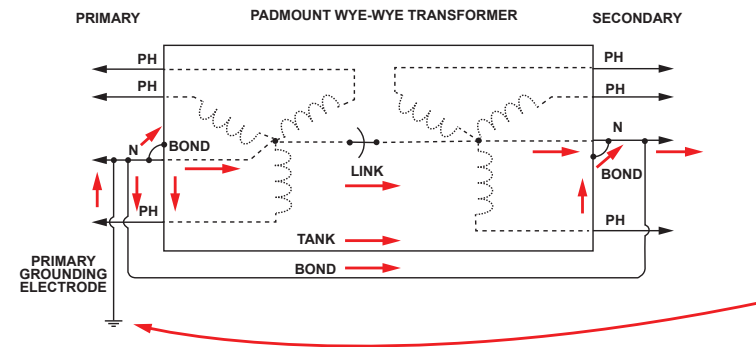

Figure 6: Three-phase pad-mounted transformer connections allowing CP current flow



Remediation of the utility connection to the facility CP system at a three-phase pad-mounted transformer is accomplished in Figure 7, showing the addition of a decoupler connected between the primary and secondary neutrals, with removal of the secondary neutral bushing ground strap from the tank. The tank remains grounded to the primary neutral and local grounding electrode. If an internal link bonds primary and secondary neutrals inside the tank, this link must be opened, or the transformer changed out for a unit that does not have this internal link.

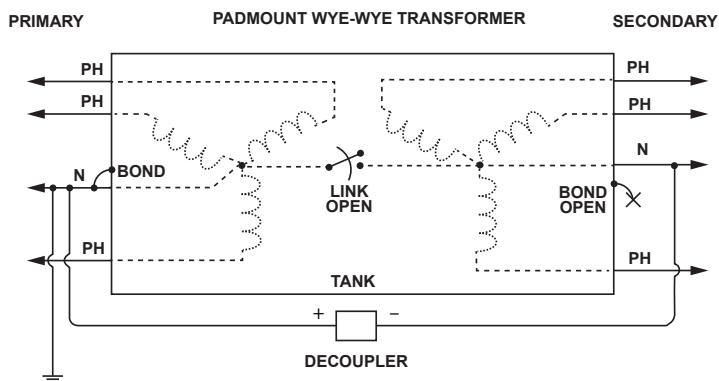

Figure 7: Decoupler installation at a three-phase pad-mounted transformer

## DECOUPLERS EXPLAINED

To understand how a decoupler is allowed in this location and can be trusted to retain the necessary bonding between the two systems, a review of decoupler background is needed. Dairyland pioneered solid-state isolation and safety grounding devices for the utility and oil/gas pipeline markets starting in the 1980s. These bi-directional, two-terminal devices feature power semiconductor-based isolation and switching, with energy capability in excess of utility system fault current and typical lightning exposures. With fail-safe construction, exposure to current/time in excess of the device ratings merely results in an uneventful fail-shortened condition, hence the term “fail-safe.” The device normally blocks dc and conducts ac (presenting an impedance of 0.01 ohm to 60Hz frequency) up to a predetermined voltage threshold of typically several volts. During an abnormal event, upon reaching the voltage threshold the decoupler instantly switches to the fully conducting mode, clamping voltage at low and safe levels. After the event, the voltage drops below the threshold and the decoupler automatically switches back to the dc blocking/ac conducting mode. For this application, the key decoupler rating is the ac fault energy capability, discussed below.

Due to the various applications addressed by decouplers, Dairyland holds multiple certifications for device use. These include certification by Underwriters Laboratory (UL) for use in hazardous locations, various environmental conditions,

and most importantly for utility decoupling, meeting the definition of an “effective ground fault current path,” per the US National Electrical Code and Canadian Electrical Code. While use for primary-to-secondary decoupling does not require compliance to electrical codes for secondary electrical systems, certification assures the user that the devices are truly fail-safe (fail shorted) and provide safety bonding and grounding whether functional or failed.

Actual performance of Dairyland decouplers in this utility decoupling application for over 20 years involving extensive use throughout North America has resulted no known product failures. Instead, marked improvement in cathodic protection of the target facility is the typical result.

Power utilities may recognize this application as being related to neutral-to-earth voltage (NEV) problems on farms, where a similar approach is used to fully isolate (ac and dc) a farm grounding system from the utility utilizing a Dairyland product called the Neutral Isolator (model VTNI). Decouplers evolved from the neutral isolation application and are installed in the same manner (with one minor difference regarding secondary neutral grounding, covered later). Dairyland has a long history with both applications. Decouplers should be used for the application covered in this guide, as these provide a greater range of fault ratings, a lower device threshold, and the ability to only block dc while appearing ac continuous. Neutral Isolators are used specifically in rural farm applications, where ac fault current is limited and only ac isolation is needed for NEV concerns.

## KEY RATINGS FOR UTILITY DECOUPLING

For this application, decouplers are chosen with ac fault capability in excess of the utility primary phase-to-ground current for the clearing time. This addresses line-to-ground faults and transformer winding failure. When sized in excess of this exposure, the decoupler re-bonds the two systems during the fault or lightning event, without failure, then returns to the normal dc blocking and ac conducting mode. There is no lifetime limitation to the product when applied within the energy ratings published for the device. AC fault capability of the Dairyland PCR family of decouplers is shown in Table 1.

Model	Fault Current Rating			
	1 cycle	3 cycle	10 cycle	30 cycle
PCR-3.7KA	6,500	5,000	4,200	3,700
PCR-5KA	8,800	6,800	5,700	5,000
PCR-10KA	20,000	15,000	12,000	10,000
PCR-15KA	35,000	27,000	21,000	15,000

Table 1: AC fault capability of Dairyland model PCR decouplers

Other device ratings are less important than the ac fault capability for this application but should be considered briefly.



## Threshold voltage

The device voltage threshold of  $-2/+2V$  or  $-3/+1V$  applies to that voltage measured between the device terminals, which is also the primary-to-secondary neutral/grounding system voltage difference, and either of these standard values are normally adequately above the system voltage. The voltage difference between the two grounding systems is typically not very high, hence the standard decoupler threshold voltage choices are adequate.

## Steady-state ac current

In this application, there should be not be steady-state ac current flow between the two grounding systems, so this condition is well within the notable ac steady-state capacity of a Dairyland decoupler.

## Hazardous locations

For a decoupler located at an electrical service, the installation site would not likely be considered a classified hazardous area, although all typical Dairyland decouplers have at least a Class I, Division 2 (and also Zone 2) certification for hazardous location use.

## Environmental

Decoupling primary-to-secondary involves decoupler placement at the transformer, which would be an above grade location, hence the standard rating of NEMA 4X or better is adequate. Should there be a need for decoupler placement in a vault or below grade site, contact Dairyland.

## ALLOWANCE FOR USE

While solid bonding is the default connection between primary and secondary grounded neutral systems for utilities, decouplers can be installed to mitigate the cathodic protection effects of a direct bond. Dairyland certification for “effective ground fault current path” and related testing assures that safety bonding will be retained. As supplemental information, utilities may be familiar with National Electric Safety Code (NESC) section 97D2, which addresses complete primary-to-secondary isolation for the specific purpose of minimizing transfer of primary neutral-to-earth ac voltage to a secondary customer, typically a farm. Section 97D2 outlines what is needed to provide safe isolation. Decouplers install in exactly the same manner but have the added benefit of keeping the two systems ac continuous (while providing dc isolation up to several volts), so from an ac perspective, a decoupler installation does not change the power utility system. For example, upon review by the Wisconsin Public Service Commission many years ago, their guidance to utilities was: “The manufacturer’s directions from Dairyland reference the NESC for proper installations. Since this is not an isolation device the NESC provisions for isolators does not apply.

You do however install the device in the same circuit located at the bond between primary and secondary at the utility transformer.” The PSC goes on to say that the addition of a secondary neutral grounding electrode per NESC 97D2 is not applicable here, as the decoupler retains the ac continuity between primary and secondary. Utilities are therefore able to install a decoupler to solve their customer’s CP problems, but also benefit from reducing interference with their own grounding electrodes.

## INSTALLATION IN SERIES IN NEUTRAL NOT ALLOWED

To dispel one common misconception, decouplers are never installed in series in current-carrying neutral conductors. Proper installation involves placement of the decoupler in safety grounds and bonds that connect to a system neutral, without being connected in series in the neutral. Connections to the neutral via equipment grounding conductors, buses, and electrodes are what cause CP problems, which can be remediated via a correctly-placed decoupler.

## OWNERSHIP AND TESTING

### Testing prior to purchase

Typically, owners of cathodically protected facilities approach the appropriate power utility with the request for decoupling, due to the negative effect on the facility CP system. Testing prior to purchase can confirm that decoupling will be effective in improving CP system performance. The secondary customer’s cathodic protection personnel can be present to take readings as the utility temporarily separates the primary and secondary neutral connections for the purpose of testing. (The utility service may need to be interrupted momentarily during the test, for safety.) If an open circuit can be established during the test, CP personnel can determine if the dc potentials (and current demand) have improved. This temporary isolation for test reflects the same dc condition as when a decoupler has been applied, and the client can then know that decoupling would be effective. If an open circuit, and associated improvement in CP potentials, cannot be achieved, then a metallic bypass still exists, which is addressed below.

### Ownership and on-going testing

After determining the appropriate decoupler ac fault rating from utility-provided data, a decoupler can be purchased by the facility owner and supplied to the utility. Installation is by the utility, or their contractor, at the transformer, as in Figures 5 and 7. The decoupler is located on the utility side of the meter and is therefore owned by the utility. However, this maintenance-free device does not need to be checked by the utility following installation. The utility customer maintains their CP system in the facility, which is affected by the power



utility grounding system when directly bonded, therefore the customer will be quickly aware of unacceptable CP potentials or excessive current demand. Resulting effect upon the distribution system grounding electrodes is easily measured by CP personnel, as they can see the potential shift on the copper from normal (native) values and alert the utility of the need for additional testing or decoupler inspection. To date, any subsequent system short found between primary and secondary grounding systems after decoupler installation has been due to other utility bonds or bypasses.

### Installation

For pole type transformer installations, the decoupler mounting channel is attached directly to the pole via lag bolts, located usually slightly below the transformers. The products are suitable for outdoor mounting without the need for an additional enclosure. Pad-mounted transformer installations commonly have a secondary pedestal housing the decoupler nearby, with underground cables connecting to the primary and secondary neutrals.

### Transformer bond bypass

Bonding connections at any transformer installation must be cleared so that only the decoupler connects the primary and secondary neutrals and associated grounding systems. These include the secondary neutral bushing tank grounding strap and any equivalent external wired bond between the two. In addition, if a three-phase pad-mounted wye-wye transformer has an internal bond between the two neutrals, this link must be opened. In the case that the link is not accessible, the transformer must be exchanged for a unit that has isolated primary and secondary neutrals.

### Phone sheath bond bypass

One additional bond between primary and secondary grounding systems that exists in almost all cases is the phone company metallic sheath that ties to the distribution neutral grounding system and also bonds to the facility grounding system, causing a bypass around the decoupler. If all transformer bonds have been correctly addressed and cathodic protection potentials have not improved, the phone sheath is the most likely bypass. The phone company can provide an open point in their sheath to address this, typically in their pedestal near the facility, which makes this open point safely inaccessible to the public.

### Fence and grounding grid bond bypass

Some facilities, typically with larger pad-mounted or substation class transformers, may have fencing and grounding near the transformer, which may tie to fencing and grounds at cathodically protected facilities that they serve and therefore bond primary and secondary systems independent of transformer decoupling. Bonding between grounding grids must then be separately decoupled at each connection. Continuous metallic fencing can have a section of electrically insulating material added in place of metallic material to separate the facilities and achieve CP isolation. Thought should be given to step and touch voltage distribution during an ac fault event, relative to non-continuous fencing, including evaluation of fencing bonds to grounding systems. Keep in mind that if a decoupler is used associated with CP isolation in facilities, the decoupler references the structures to each other for safety while providing dc isolation. Therefore, if a facility was properly designed and evaluated for step and touch voltage issues under abnormal conditions, the addition of a decoupler does not change the facility from an ac safety perspective.

### ADDITIONAL INFORMATION

Information about specific products, including ratings, certifications, and installation instructions, can be found on the Dairyland website [www.dairyland.com](http://www.dairyland.com).

### SUMMARY

Without the use of solid-state decouplers, dc isolation of cathodically protected facilities would be impossible, due to the connections that normally exist between utility and customer grounding systems at the electrical service. Decoupling provides the CP isolation that is needed, while retaining ac steady-state and fault continuity between the two systems for safety. Standard installation locations on utility services make decoupling straightforward, once the power utility and the owner of the cathodically protected facility understand that this option exists.

Dairyland technical support is available to address questions about this application and can be reached at [techsupport@dairyland.com](mailto:techsupport@dairyland.com).