

INSTRUCTIONS

GRADIENT CONTROL MAT (GCM)



DAIRYLAND
ELECTRICAL INDUSTRIES

ALWAYS RUGGED. ALWAYS RELIABLE.



INTRODUCTION

Most gradient control mats are designed and installed around above ground pipeline appurtenances to limit power frequency voltages. The Dairyland gradient control mat is designed to also limit potentially hazardous voltages due to lightning, a much more difficult task. Step potentials are inherently controlled by the design of the mat (grid wire size, grid spacing, etc.), but the touch potential that a worker may be subject to is determined both by the mat design and the installation; therefore, these installation guidelines must be followed to provide maximum protection from lightning-caused voltages.

The reason for this is that conductors inherently have inductance and when a very fast rising current, such as from lightning, flows through the conductor from the pipeline to the mat a significant voltage per unit of conductor length is developed. This voltage drop adds directly to the touch potential for a worker standing on the mat. Therefore, keep conductor connections between the mat and pipeline as short as possible – as described above.

WARNING

KEEP THE CONDUCTORS SHORT!

The most significant installation factor is to keep the conductor that connects the mat to the pipeline as short as possible, preferably 8" (200 mm) or less, whether the mat is direct connected to the pipeline or connected through a Dairyland solid-state decoupler.

Materials Required for Installation

1. Gradient Control Mats (4' x 8'), GCM4-8
2. If more than one mat is required, then weld the mats together using the Dairyland mold Mold-6X and an industry standard #25 cartridge that can be purchased from any industry source. Do not join mats with compression type or bolted type connections - thermit weld only.
3. Magnesium anodes per Table 2, Section 2.1 and 2.2 in the attached Correng Report, and backfill, if not provided with the anode.
4. To thermit weld a #6 AWG anode lead or the #6 decoupler leads to the mat (if the mat is decoupled) use Mold-6X and a standard #25 CP cartridge/shot. To thermit weld a #10 or #12 AWG lead, use Mold-6X with a #15 CP cartridge/shot. Do not attach leads with compression type or bolted type connections - thermit weld only.
5. Wire cutters for 0.135" diameter steel wire (If necessary to cut out sections of the mat to fit around pipelines.)
6. A Dairyland Solid State Decoupler if used, typically Model SSD-A/B-C-D where A/B is the blocking voltage, C is the fault current rating at 30 cycles, and D is the lightning current rating in kA. The most common rating is the SSD-2/2-1.2-100 for gradient control mat decoupling. Reference the Dairyland technical literature for model SSD for ratings and outline drawings.
7. Decoupler conductors, 12" (300 mm) or 36" (900 mm) with factory installed terminals (one end only), order MTL-6-12 or MTL-6-36, with each kit containing two #6 AWG conductors. It is recommended that two conductors per decoupler terminal are used, but cut off all excess conductor to make connections as short as possible.
8. Mounting of decoupler:
 - By banding: Banding material to be selected/purchased by user
 - By mounting to 8 mm pin brazed studs. Equipment/studs/ceramic ferrules by user. Requires one Hex Coupling Nut from Dairyland, model #HCN-M8
 - By securing to a post adjacent to the pipeline: User furnished.

The first two mounting methods are illustrated in sheets 2 and 3 of the attached drawing 100103.
9. Sealant for all thermit welds: Denso LT tape (Available from Dairyland in 2"x33'rolls)
10. OPTIONAL: Crushed limestone to cover mat 6" (Use clean washed stone only if limestone is not available.)



INSTALLATION INSTRUCTIONS

WARNING

During installation, the voltage on the structure may rise to an unsafe level (i.e., due to induced AC, AC fault or lightning on the structure). Sparking and current flow may occur when making or breaking connections between the structure and the gradient control mat. Assure that this does not occur in hazardous locations where gases or vapors may be present. All necessary safety precautions must be taken by the user to avoid unsafe worker conditions, including arcing, in accordance with applicable industry and/or company-required practices. Dairyland provides suggested procedures for installing and operating this equipment (See the section on Worker Safety). But the user must be responsible for and approve the procedures to be used by its workers when installing the equipment because Dairyland cannot be familiar with each user's safety guidelines.

WARNING

Do not pin braze or weld in hazardous locations where explosive gases or vapors may be present.

Worker Safety

For worker safety during installation, it is recommended that the user obtain certain equipment; namely a pair of electrically insulated gloves, a shorting cable approximately 3 ft (0.91 m) long with insulated clamps on each end, and a multi-meter to measure AC voltage. (Of these items, Dairyland offers a suitable 3 ft long 1/0AWG shorting cable with insulated clamps, Model# BCL-1/0 for all decoupler ratings.) The following installation procedure assumes that these items are available. It is suggested that a grounding jumper be used as a safety precaution in the event the lead to the structure rises to an unsafe potential when it is disconnected during the installation process or if an electrical disturbance occurs while the decoupler is being installed. Be sure to remove the grounding jumper after the decoupler is completely installed. If the structure voltage is not at a safe touch potential (i.e., >15VAC to ground per NACE SP0177), then insulating gloves should be used.

Install mats and anodes as illustrated in the attached Correng Report. If a decoupler is used, refer to the attached decoupler drawing 100103.

1. Remove topsoil to a uniform depth of approximately 6" (150 mm) in an area that extends beyond the lateral mat dimensions. At the anode locations, excavate an additional 36" (900 mm) depth to the lateral dimensions of a horizontally oriented anode as depicted in the Correng Report. Apply backfill material around the anode (if the anode is not already bagged with backfill), and refill the hole with native soil, leaving the anode wire extended beyond the soil surface for later attachment to the mat.
2. Orient adjacent mats as follows: Flip the adjacent mat over so that the top grid wires on one mat are oriented 90° with respect to the top grid wires on the adjacent mat. This will enable the outer grid wires on adjacent mats to be placed directly next to each other, a requirement for the grid wires to fit properly in the thermit welding mold.
3. Locate the position of vertical pipe segments or other structures that will protrude through the mat, and using wire cutters, remove the unneeded portions of the mat so that the mat wires are no closer than 3" (75 mm) to the pipe at any point, which will avoid contact and abrasion to the pipe coating.
4. Place the mat segments in position around the structure, in the excavated area. When multiple mats are required for a given site, the adjoining mats should be thermit welded together approximately every 18" using the mold and weld charge recommended. Do not substitute or use any compression or bolted type connection.
- 5.) Weld the #6 AWG anode conductors to the mat as illustrated in the Correng Report using the mold and weld charge. For anodes with #10 or #12 AWG conductors, use Mold-6X with a #15 CP cartridge. Do not substitute or use any compression or bolted type connection.
6. If the mat is to connect to the pipe through a decoupler, mount the decoupler as close to the mat as feasible, taking into account the depth of backfill or crushed stone that may be used to cover the mat. The mounting method for the decoupler should have been pre-determined by the user and may consist of banding to the pipe wall, mounting by using 8 mm studs pin brazed to the pipe, or by mounting to a post adjacent to the pipe that is to be connected to the mat. All mounting is to be user furnished, except, if 8 mm studs are pin brazed to the pipe, a hex coupling nut kit is required from Dairyland (#HCN-M8) to make the connection from one decoupler terminal directly to the pipe wall. See the attached figures for various decoupler mounting methods.



7. Make conductor connections from the appropriate decoupler terminal to the closest section of mat with the short-est lead that will still allow welding of the conductor to the mat using the Mold-6X for #6 AWG. Two #6 conductor connections are recommended from each decoupler terminal as this also helps to minimize lead inductance, with one conductor set to the pipe and the other set to the mat, each preferably less than 8" (200 mm) long. Of the two Dairy-land decoupler conductor lengths available, the 36" (900 mm) long conductors are never recommended when limiting touch potentials due to lightning is of concern, but this length is acceptable for power frequency voltages. When connections are made to adjacent mats as illustrated in Figure 1 (bottom view) of the Correng Report it is desirable to mount the decoupler so one conductor goes to each mat with the shortest possible conductor length.

Dairyland recommends installing a grounding loop approximately 3' from the outer edge of the Dairyland GCM matted area. The conductor should be redundantly connected (two conductors at each connection point) in at least two separate locations on the GCM (preferably opposite of one another). For larger matted areas, connect the grounding loop multiple times with a maximum spacing of 75' between connections around the perimeter of the matted area.

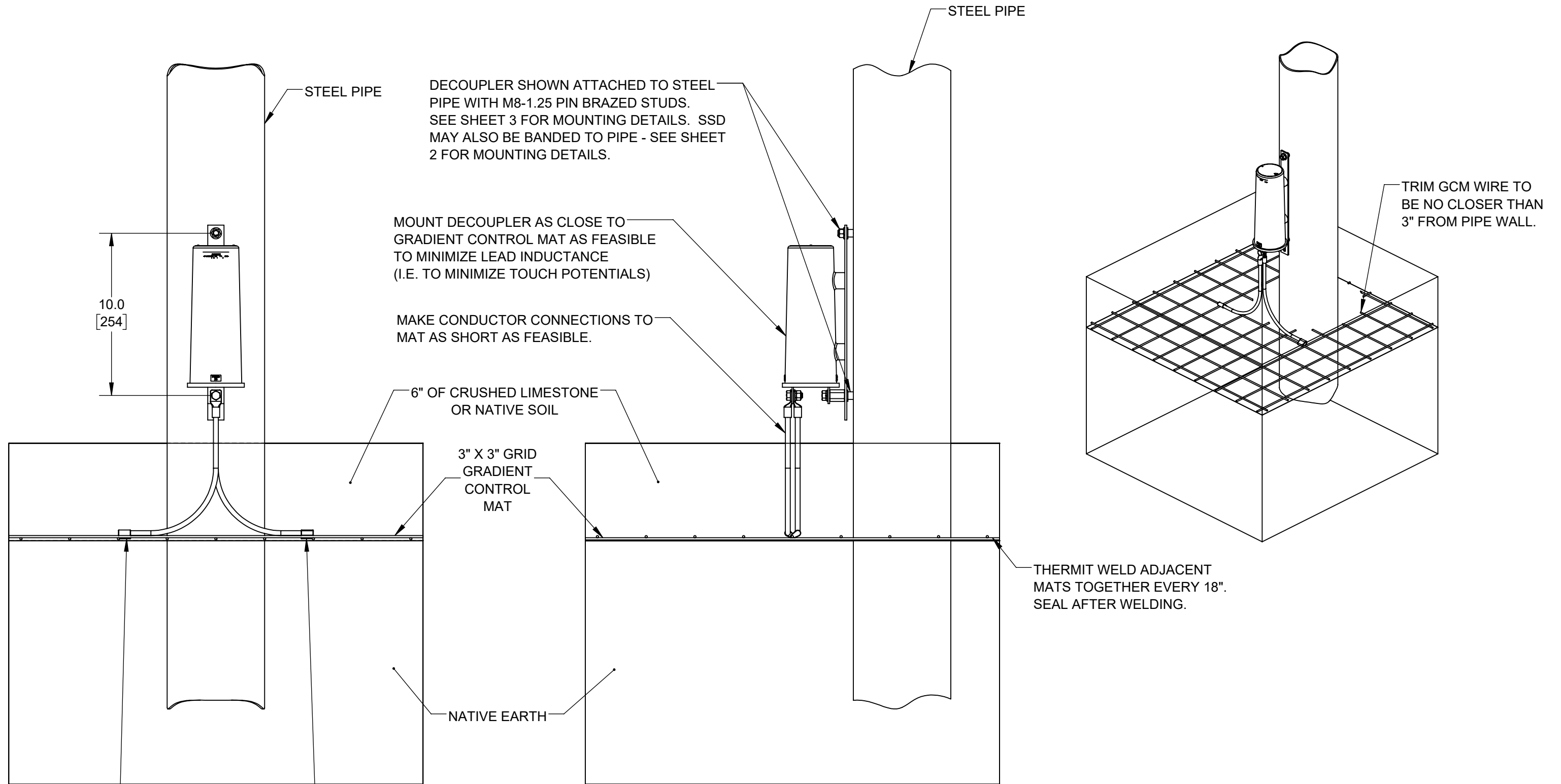

8. After all welding is complete (i.e., all mat to mat and lead to mat welds), seal around and beyond the end of each weld with two or more layers of Denso LT petrolatum tape or other user approved sealant. When the Denso tape is used, a 4" long piece of the 2" wide tape is required to seal each weld.
9. Cover the entire gradient control mat with 6" of either native soil or crushed limestone. Extend the covering at least several feet beyond the outer edges of the mat on all sides.

NOTE: THIS DRAWING TO BE USED IN COMBINATION WITH GRADIENT CONTROL MAT INSTALLATION INSTRUCTIONS

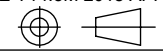

10.0
[254]

THERMIT WELD #6 AWG.
DECOUPLER CONDUCTORS AND
ANODE CONDUCTORS TO MAT.
SEAL AFTER WELDING.

ASME Y14.5M 2018 APPLIES  UNLESS OTHERWISE SPECIFIED DIMENSIONS ARE IN INCHES. COMPUTER-GENERATED DRAWING DO NOT EDIT MANUALLY.	MATERIAL:	NA	DRAWN:	DATE DRAWN:	 DAIRYLAND ELECTRICAL INDUSTRIES, INC. P.O. BOX 187 STOUGHTON, WI 53589 608-877-9900 DAIRYLAND.COM		
	FINISH:	NA	DWG APPROVAL:	DATE APPROVAL:			
.XXX = ±.005" .XX = ±.01" .X = ±.03" ANGLES = ±1°			TITLE: DECOUPLING OF GRADIENT CONTROL MAT: TYPICAL INSTALLATION				
THE INFORMATION CONTAINED IN THIS DRAWING IS THE SOLE PROPERTY OF DAIRYLAND ELECTRICAL INDUSTRIES, INC. ANY REPRODUCTION IN PART OR WHOLE, WITHOUT THE WRITTEN PERMISSION OF DAIRYLAND ELECTRICAL INDUSTRIES, INC. IS PROHIBITED.			SHEET: 1 OF 4	DWG SIZE: B	SCALE: 1:6	REV: C	PART #: 100103

NOTE: THIS DRAWING TO BE USED IN COMBINATION WITH GRADIENT CONTROL MAT INSTALLATION INSTRUCTIONS

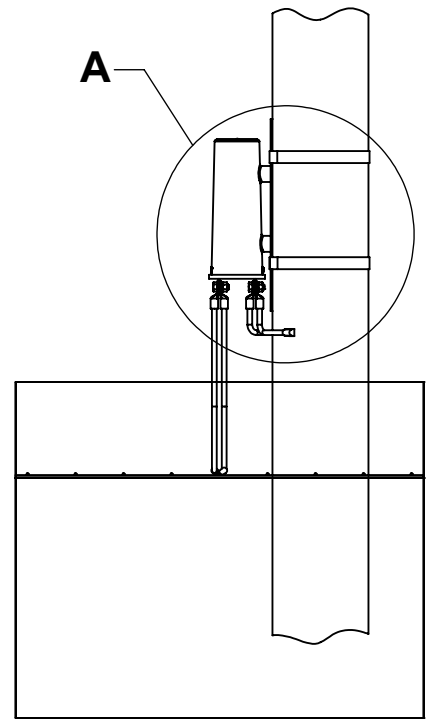

SSD MOUNTING BRACKET FURNISHED

SSD

STATION PIPE



BANDING TO BE PROVIDED BY USER

#6 AWG CONDUCTORS WITH TERMINALS ATTACHED ON ONE END PLUS NUTS, BOLTS, AND WASHERS AVAILABLE FROM DAIRYLAND. SPECIFY #MTL-6-12 FOR 12" (300mm) OR MTL-6-36 FOR 36" (900mm) FOR A SET OF TWO CONDUCTORS. TWO CONDUCTORS TO EACH SSD TERMINAL ARE RECOMMENDED. OTHER CONDUCTOR ENDS ARE UNFINISHED.

FOR CONDUCTOR CONNECTIONS TO A STEEL PIPE, A THERMIT WELD IS RECOMMENDED. MAKE CONDUCTOR LENGTHS BETWEEN SSD BUS AND PIPE AS SHORT AS POSSIBLE TO MINIMIZE INDUCTIVE VOLTAGE DROP DUE TO LIGHTNING AND SWITCHING TRANSIENTS.

(+) (-)

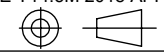
DETAIL A
SCALE 1 : 2

ASME Y14.5M 2018 APPLIES  UNLESS OTHERWISE SPECIFIED DIMENSIONS ARE IN INCHES. COMPUTER-GENERATED DRAWING DO NOT EDIT MANUALLY.	MATERIAL:	DRAWN: JPW	DATE DRAWN: 2017-02-20	 DAIRYLAND ELECTRICAL INDUSTRIES, INC. P.O. BOX 187 STOUGHTON, WI 53589 608-877-9900 DAIRYLAND.COM			
	FINISH: NA	DWG APPROVAL: JSJ	DATE APPROVAL: 01/29/2025				
.XXX = ±.005" .XX = ±.01" .X = ±.03" ANGLES = ±1°	TITLE: DECOUPLING OF GRADIENT CONTROL MAT: BANDING SSD TO PIPE		SHEET: 2 OF 4	DWG SIZE: B	SCALE: 1:12	REV: C	PART #: 100103
THE INFORMATION CONTAINED IN THIS DRAWING IS THE SOLE PROPERTY OF DAIRYLAND ELECTRICAL INDUSTRIES, INC. ANY REPRODUCTION IN PART OR WHOLE, WITHOUT THE WRITTEN PERMISSION OF DAIRYLAND ELECTRICAL INDUSTRIES, INC. IS PROHIBITED.							

NOTE: THIS DRAWING TO BE USED IN COMBINATION WITH GRADIENT CONTROL MAT INSTALLATION INSTRUCTIONS

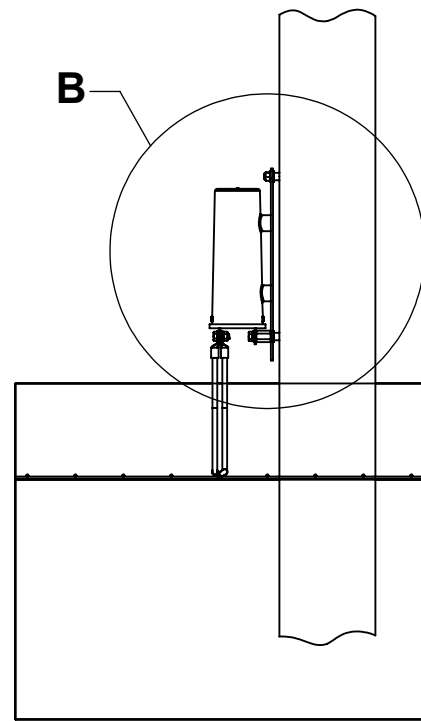

THIS INSTALLATION METHOD REQUIRES PIN BRAZING EQUIPMENT AND M8 -1.25 THREADED STUDS FURNISHED BY OTHERS. INSTALL STUDS TO SPACING SHOWN +/- 0.10" OR +/- 2.5mm. CONTACT DAIRYLAND FOR FURTHER INFORMATION

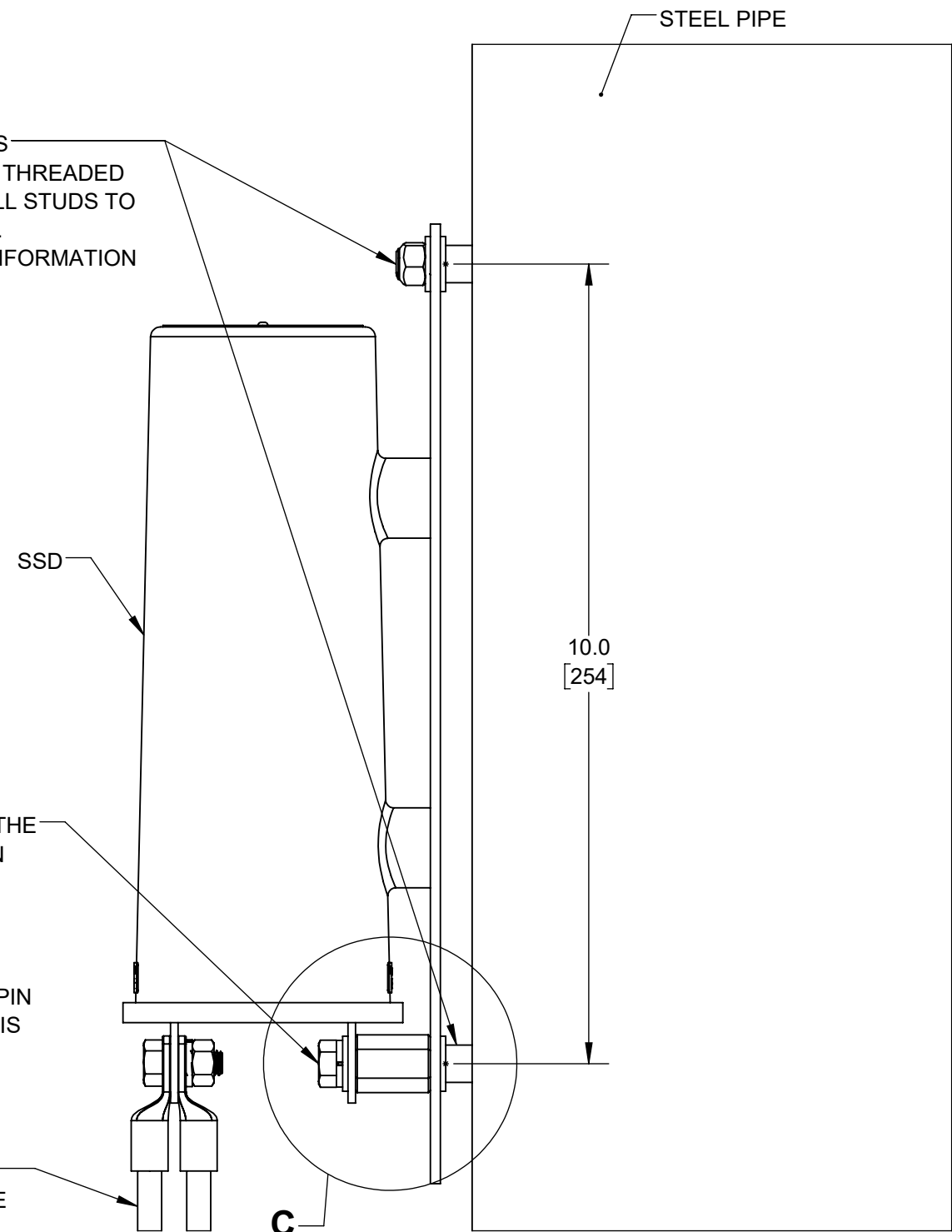

TO CONNECT NEGATIVE TERMINAL TO PIPE VIA THE PIN BRAZED STUD, SPECIFY #HCN-M8 TO OBTAIN THE HEX COUPLING NUT PLUS M8 BOLT AND WASHERS REQUIRED. USE WITH SSD MODEL: SSD-2/2-1.2-75

HEX COUPLING NUT IS FIRST TIGHTENED ONTO PIN BRAZED STUD, THEN M8 BOLT (WITH WASHERS) IS TIGHTENED INTO THE COUPLING NUT.

#6 AWG CONDUCTORS WITH TERMINALS ATTACHED ON ONE END PLUS NUTS, BOLTS, AND WASHERS AVAILABLE FROM DAIRYLAND. TWO CONDUCTORS ARE RECOMMENDED TO THE SSD TERMINAL. OTHER CONDUCTOR ENDS ARE UNFINISHED.

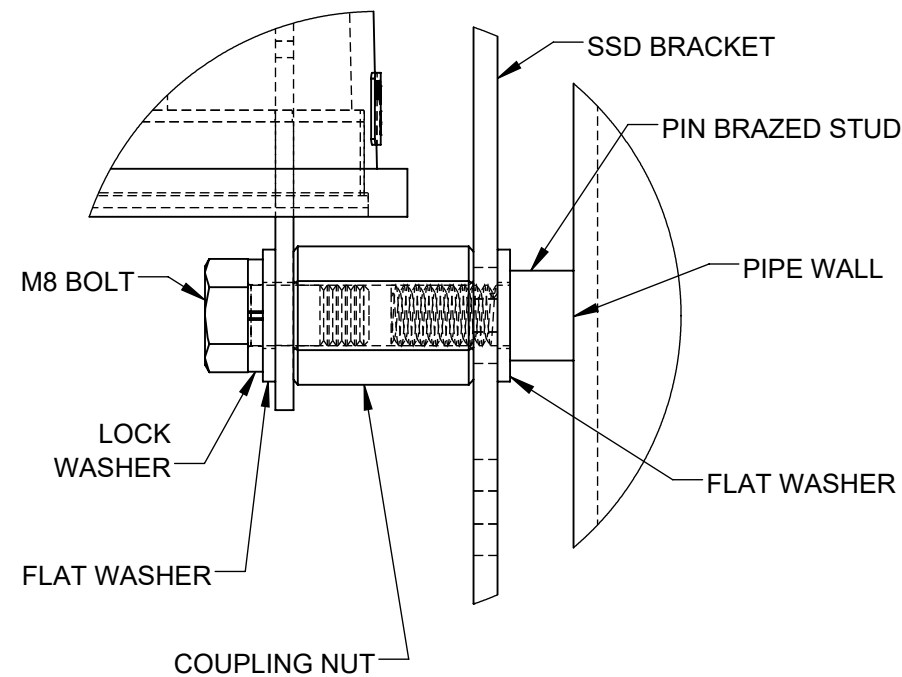

**DETAIL C
SCALE 1 : 1**

**DETAIL B
SCALE 1 : 2**

ASME Y14.5M 2018 APPLIES UNLESS OTHERWISE SPECIFIED DIMENSIONS ARE IN INCHES. COMPUTER-GENERATED DRAWING DO NOT EDIT MANUALLY.	MATERIAL:	NA NA	DRAWN: JPW	DATE DRAWN: 2017-02-20	 DAIRYLAND ELECTRICAL INDUSTRIES, INC. P.O. BOX 187 STOUGHTON, WI 53589 608-877-9900 DAIRYLAND.COM			
	FINISH:	NA	DWG APPROVAL: JSJ	DATE APPROVAL: 01/29/2025				
.XXX = ±.005" .XX = ±.01" .X = ±.03" ANGLES = ±1°	THE INFORMATION CONTAINED IN THIS DRAWING IS THE SOLE PROPERTY OF DAIRYLAND ELECTRICAL INDUSTRIES, INC. ANY REPRODUCTION IN PART OR WHOLE, WITHOUT THE WRITTEN PERMISSION OF DAIRYLAND ELECTRICAL INDUSTRIES, INC. IS PROHIBITED.		TITLE: DECOUPLING OF GRADIENT CONTROL MAT: PIN BRAZED STUD CONNECTION TO PIPE	SHEET: 3 OF 4	DWG SIZE: B	SCALE: 1:12	REV: C	PART #: 100103

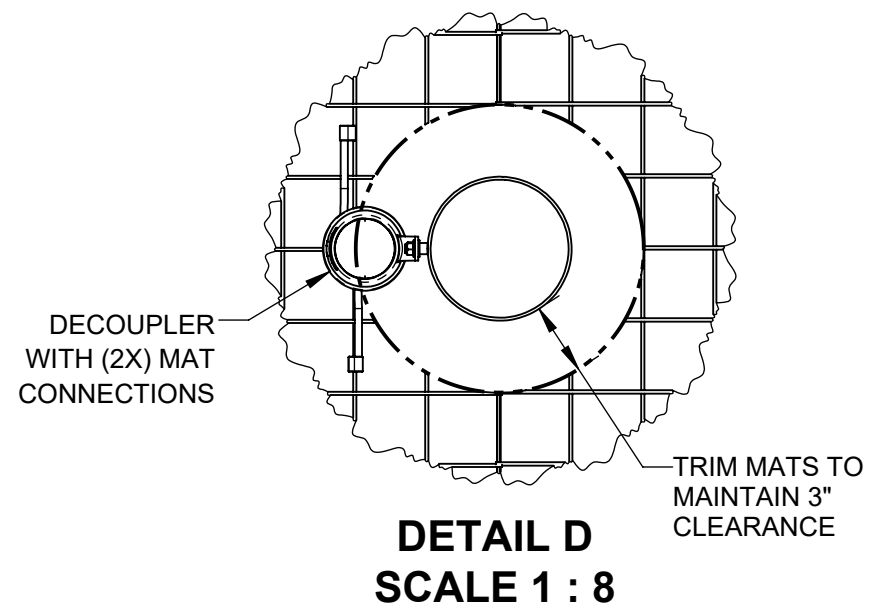
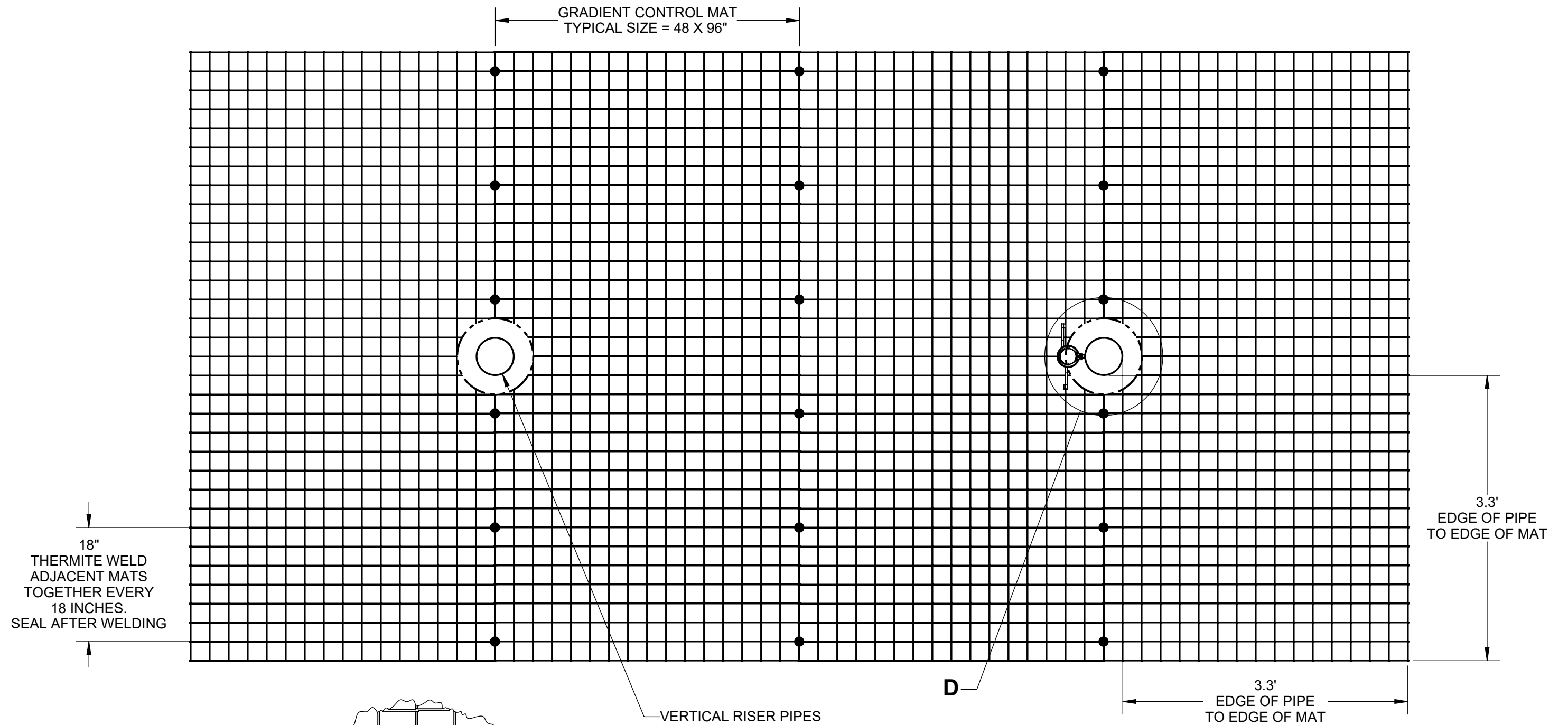

ASME Y14.5M 2018 APPLIES 	MATERIAL: NA	DRAWN: JPW	DATE DRAWN: 2017-02-20	 DAIRYLAND ELECTRICAL INDUSTRIES, INC. P.O. BOX 187 STOUGHTON, WI 53589 608-877-9900 DAIRYLAND.COM
UNLESS OTHERWISE SPECIFIED DIMENSIONS ARE IN INCHES. COMPUTER-GENERATED DRAWING DO NOT EDIT MANUALLY.	FINISH: NA	DWG APPROVAL: JSJ	DATE APPROVAL: 01/29/2025	
.XXX = ±.005" .XX = ±.01" .X = ±.03" ANGLES = ±1°	THE INFORMATION CONTAINED IN THIS DRAWING IS THE SOLE PROPERTY OF DAIRYLAND ELECTRICAL INDUSTRIES, INC. ANY REPRODUCTION IN PART OR WHOLE, WITHOUT THE WRITTEN PERMISSION OF DAIRYLAND ELECTRICAL INDUSTRIES, INC. IS PROHIBITED.		TITLE: DECOUPLING OF GRADIENT CONTROL MAT: TYPICAL INSTALLATION	
SHEET: 4 OF 4		DWG SIZE: B	SCALE: 1:16	REV: C
				PART #: 100103