

The Variable Threshold Neutral Isolator (VT/NI)



Installation Instructions

PRODUCT APPLICATION

These installation instructions apply to the Variable Threshold Neutral Isolator (VT/NI) Model # VT/NI-170-45.

The VT/NI is designed specifically for installation between the primary neutral of a power utility distribution system and the secondary neutral of a customer service. It performs two basic functions: (1) it reduces the neutral-to-earth voltage on the secondary neutral caused by the normal neutral-to-earth voltage on the primary neutral, and (2) it maintains the safety aspects of solidly connected primary and secondary neutrals by reconnecting these neutrals any time the voltage difference between neutrals exceeds a predetermined voltage threshold level.

PRODUCT RATING

The 60 Hz short-duration (i.e. fault current rating) is included in the Ratings Table. This product is to be applied where the available fault current/time duration from the power utility system (primary system) is less than or equal to the values given in the table of ratings.

PRODUCT INSTALLATION: POLE-TYPE TRANSFORMERS

Separating the primary and secondary neutral at a transformer is a non-standard but accepted operating procedure per the National Electrical Safety Code (NESC) Rule 97D2. The specific

Ratings for VT/NI-170-45

60 Hz AC-RMS Rating

Amperes	# Cycles ¹ t	(Amp ² sec)
3200	1	170 x 10 ³
2400	3	288 x 10 ³
1900	10	602 x 10 ³
1700	30	1445 x 10 ³

Lightning Surge Current Rating (Based on 8 x 20 μ sec waveform)

30,000 Amperes crest

60 Hz Voltage Rating

For use on 15kV, 25kV, or 35kV Class
Distribution Systems

Operating Temperature

-40°F to +140°F

(-40°C to +60°C)

instructions for installation of this product are to be provided by the utility so that all work is done in a safe manner and in accordance with the installing utility's practices and procedures. The following instructions are general in nature and are not intended as substitute for adequate training and experience in working around high-voltage electrical equipment.

(1) Install the isolator on the pole near the transformer with the lag bolts provided. The isolator must be positioned so that the clearances required by code

are maintained between all neutral conductors and any communication conductors.

(2) The primary neutral and transformer tank should be connected to one terminal of the isolator and to a primary neutral ground.

The secondary neutral should be connected to the other terminal and to a separate secondary neutral ground. To obtain isolation between the primary and secondary neutrals, disconnect the strap between the secondary neutral bushing and the tank. The primary and secondary neutral ground rods should be spaced a minimum of 6 feet apart; however, some states, such as Wisconsin, amend this code and require additional spacing to aid in isolation.

(3) The secondary grounding conductor should have 600 volt insulation; a requirement of the National Electric Safety Code (NESC).

(4) The telephone utility serving the customer should be consulted to assure that the telephone conductor shield does not effectively provide a direct connection between the primary and secondary neutral systems intended to be separated. This also applies to any other utility services that may be present (such as cable TV, etc.), causing the isolator to be by-passed.

(5) Following installation, measurements should be taken to assure proper installation and functioning of the isolator.

(6) Reference Figure 1 for installation with a typical pole-type transformer with a 120/240 volt secondary.

(7) Note: Any time there is a blown transformer fuse or lightning-caused damage of any nearby utility or on-farm equipment, it is recommended that the isolator be checked for proper functioning. Should the isolator be exposed to currents above rating such that failure would occur, failure will normally occur in the shorted mode thereby permanently reconnecting the primary and secondary neutrals. (The DC resistance between terminals of a functioning unit should be more than 5000 Ohms—

and will typically be much more—and the DC resistance of a failed unit will typically be less than one Ohm.) One lead should be removed when conducting this test. If there is a question regarding proper functioning, consult Dairyland Electrical Industries or return unit for a factory re-test.

**PRODUCT INSTALLATION:
PAD-MOUNT
TRANSFORMER**

All of the above steps apply to the installation procedure for a pad-mount transformer except that in step (1) the isolator will normally be installed in a secondary type pedestal next to the transformer as shown in Figure 2, or in the transformer cable training area.

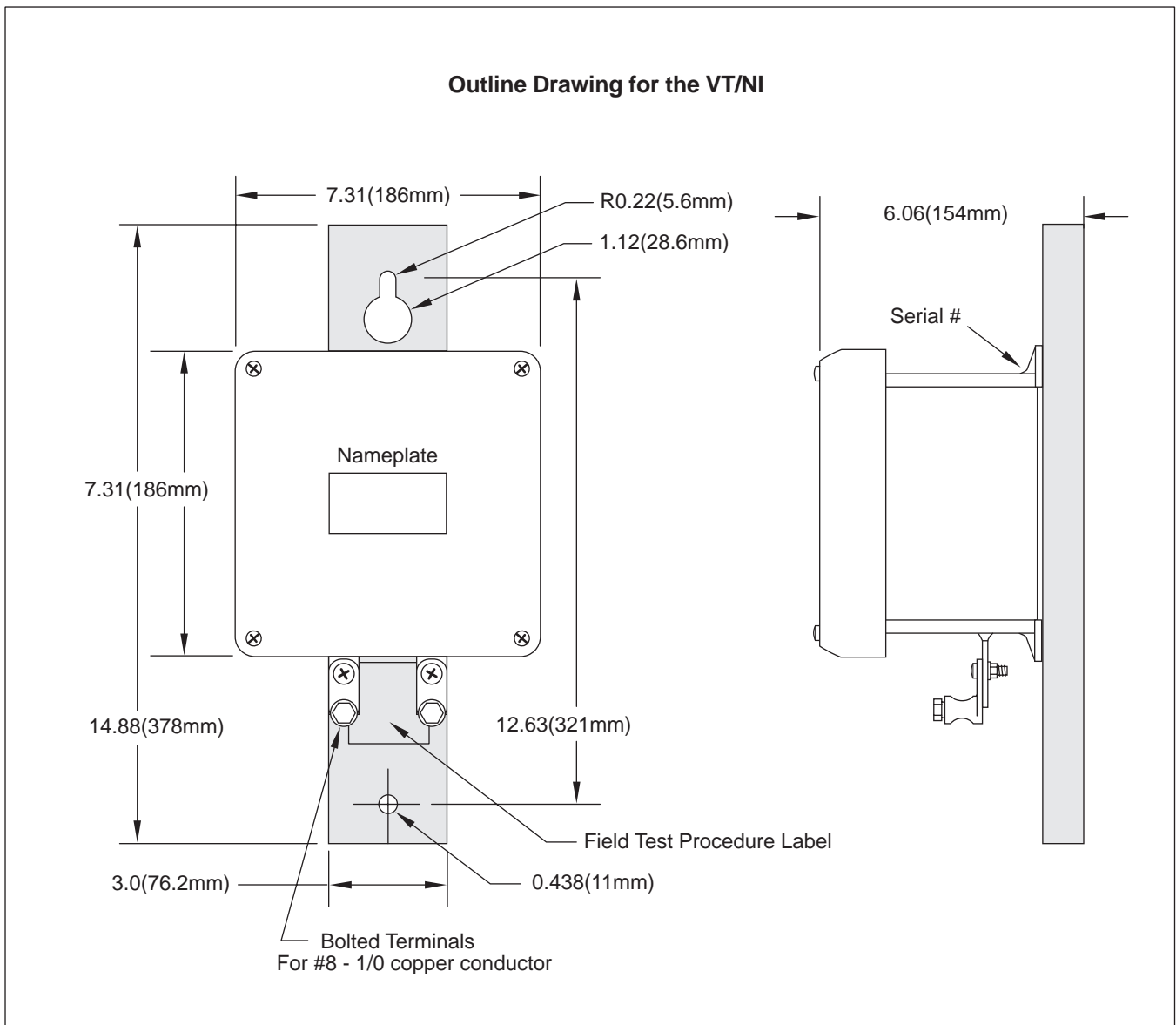
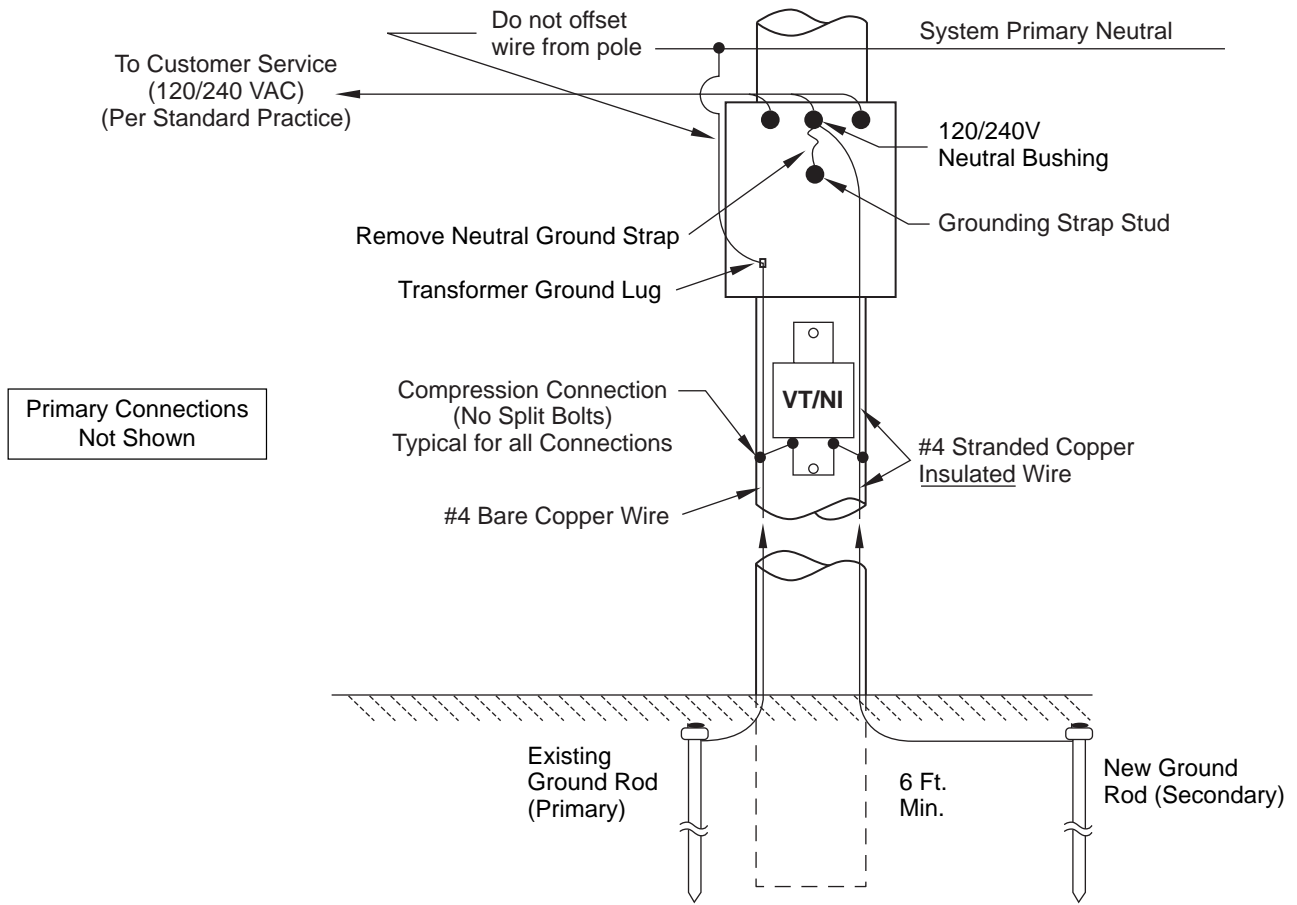
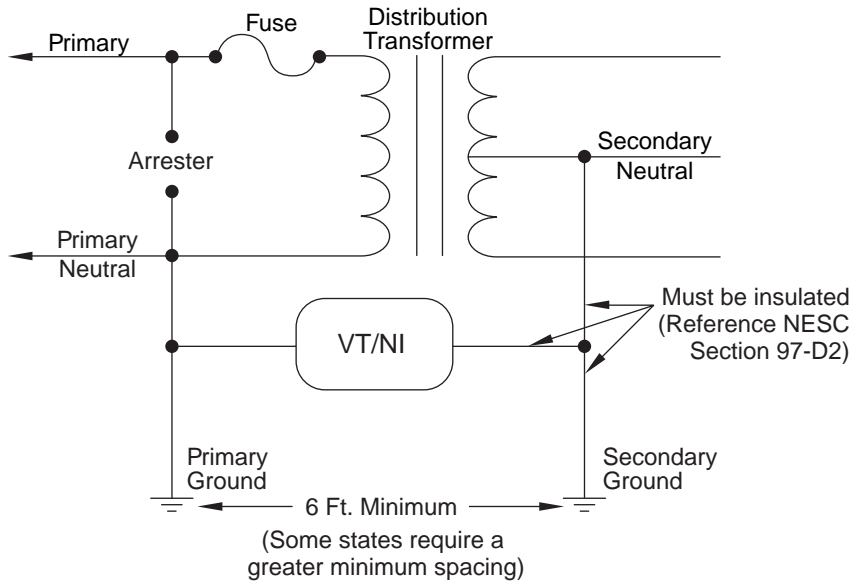

Figure 1: Neutral Isolator Installation for 120/240V Single-Phase Pole-Mount Transformer



VT/NI INSTALLATION



Note: Remove bond between secondary neutral and transformer tank.

Figure 2: Neutral Isolator Installation for 120/240V Single-Phase Pad-Mount Transformer

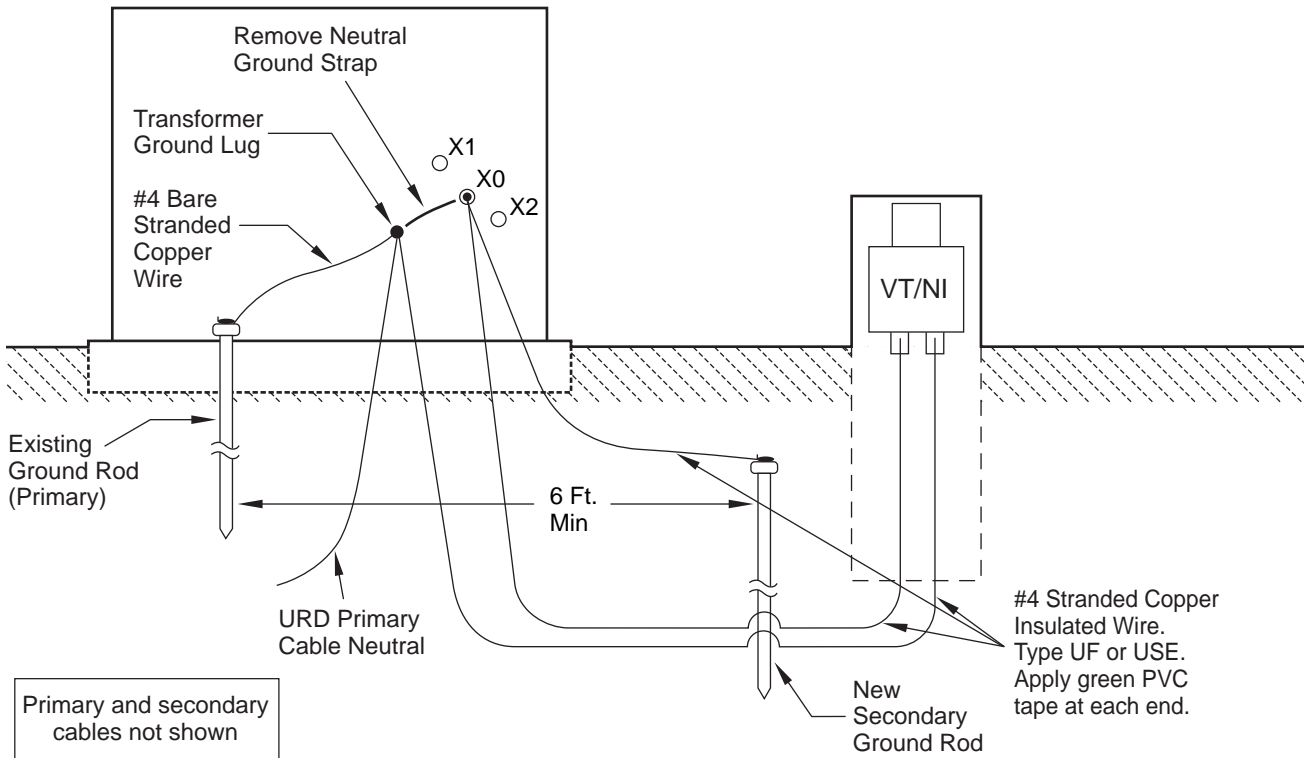

VT/NI INSTALLATION

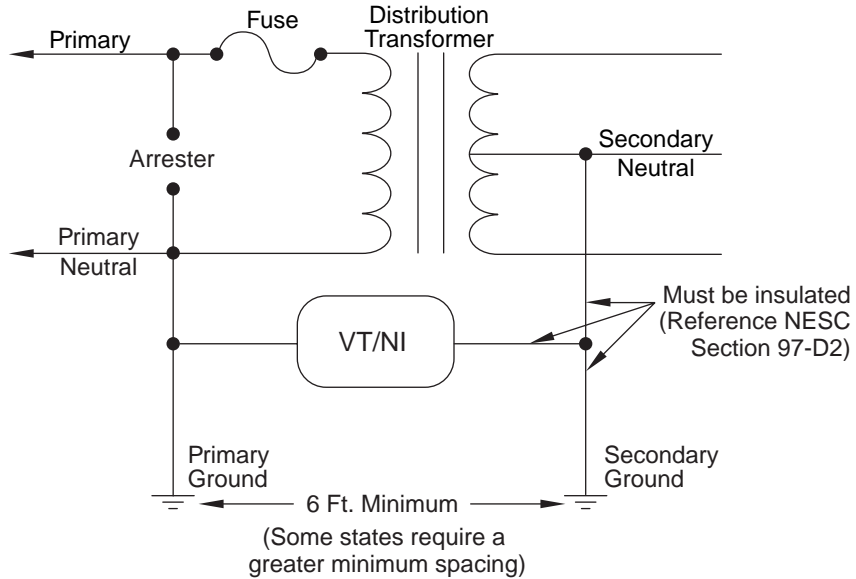

Note: Remove bond between secondary neutral and transformer tank.