

The Isolator/Surge Protector (ISP)



INTRODUCTION

The Isolator/Surge Protector (ISP) is a solid-state device with logic-controlled circuitry which simultaneously provides DC isolation and AC continuity - common requirements for protective devices used with cathodically protected systems. Its use is intended for safe electrical isolation of cathodically protected:

Systems subject to AC power faults

The ISP is designed to carry AC fault current while simultaneously limiting the voltage between its connection points to levels safe for personnel and equipment.

Systems which are coupled to an AC source

The ISP provides a low impedance path to ground for induced steady-state AC current, thereby preventing potentially hazardous AC voltage from being developed on the structure. DC isolation is maintained when carrying rated steady-state AC current.

Systems subject to lightning and/or switching transients

The ISP provides over-voltage protection due to lightning/switching transients.

ISP APPLICATIONS

It is important to recognize that cathodically protected systems which are not part of a power system may still be subject to the voltages and fault currents associated with power systems. For example, pipelines which are adja-

cent to power lines may be subject to fault currents and induced voltage due to inductive, capacitive or conductive coupling.

Typical applications include cathodically protected:

- Pipelines
- Insulated Joints
- Motor Operated Valves
- Power and Process Plants
- Fueling Facilities
- High Voltage Cable
- Storage Tanks

The ISP is primarily used where the AC fault current rating OR the DC voltage blocking rating exceeds that of the Polarization Cell Replacement (PCR) separately.

WHY ISOLATION IS DESIRABLE

Isolation is desirable because it prevents the flow of DC current from the structure being protected, thus minimizing the DC current required for corrosion protection, and thereby reducing cathodic protection costs. Isolation also minimizes the effects of stray currents which may otherwise cause a structure to corrode at a faster rate.

HOW THE ISP FUNCTIONS Under Normal Conditions

The Isolator/Surge Protector achieves both isolation and protection by presenting a significantly different imped-

ance to DC versus AC. As illustrated in Figure 1, under "normal" steady-state conditions, the ISP presents high impedance to DC and low impedance to AC. This mode is always in effect unless the absolute voltage across the terminals of the ISP exceeds a predetermined level or the AC current exceeds a predetermined level. ISPs can be furnished with voltage threshold levels of 12.5 or 20 volts peak and with current threshold levels of 30, 60 or 90 amperes at 60 Hz; and 25, 50, or 75 amperes at 50 Hz. (Higher current ratings are available upon request.) When the ISP is used for AC voltage mitigation, the induced voltage will be reduced to a small fraction of its "open-circuit" value. Therefore, the ISP can be used where the open-circuit voltage is significantly above the voltage threshold level selected.

The ISP

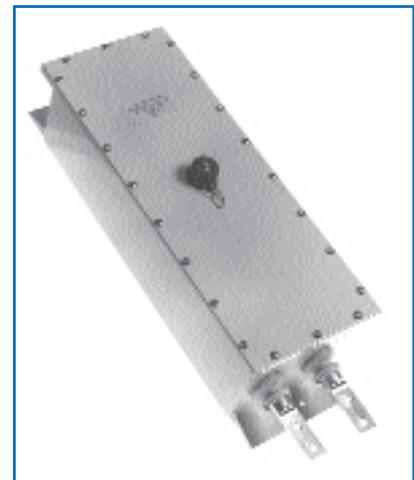
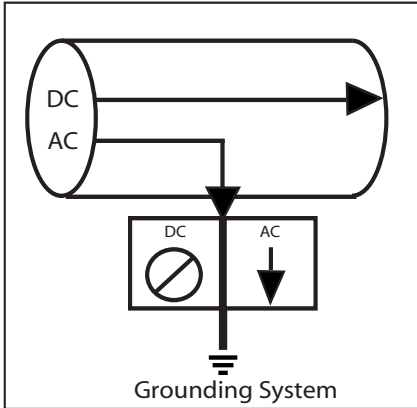

FIGURE 1 The ISP in Normal Mode For Cathodic Isolation



Under Abnormal Conditions

When the voltage across the terminals of the ISP attempts to exceed the threshold level selected, or the AC current attempts to exceed the steady-state current rating selected, the DC and AC impedance both drop to extremely low values and the ISP effectively becomes a short circuit, as illustrated in Figure 2. This prevents high voltage - potentially dangerous to personnel or equipment - from occurring between the two points to which the ISP is connected.

FIGURE 2 "Short Circuit" Mode For Over-Voltage Protection

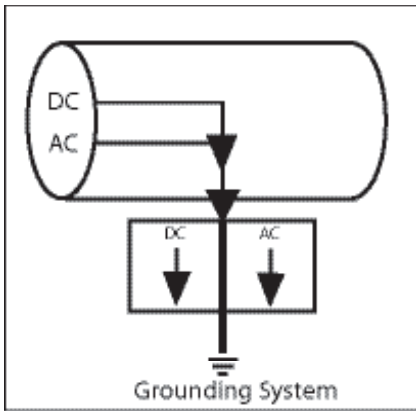

Typical situations which would cause the voltage to exceed the threshold level include AC fault currents or lightning/switching transients. When the fault or transient condition is over, logic-controlled circuitry returns the ISP to its normal operating mode of blocking DC and conducting steady-state AC.

PRODUCT RATINGS

The model number structure of the ISP is coded ISP-A-B-C-D-E-F-G-H. The following sections explain the rating code system, which is also summarized on page 6.

"A" Code: Lightning Surge Current

Two standard lightning surge current ratings are available, with values of 50,000A or 75,000A crest. In an area with moderate to high incidence of lightning, the higher rating is suggested. (A 100,000A rating is available upon request.)

These ratings should not be confused with AC fault current ratings as the waveforms associated with each are distinctly different and have different effects. These lightning surge current ratings are based on an 8 x 20 microsecond waveform considered representative of lightning. (The crest value of current is reached in 8 microseconds, after which the current decays exponentially, reaching one-half of its crest value in 20 microseconds.)

Lightning Surge Current Ratings

	"A" Code	
	50	75
Peak Amperes	50,000	75,000

For "A" select 50 or 75.

"B" Code: Voltage Threshold Level

Two choices are available for the voltage threshold level at which the ISP transitions to its shorted mode and ceases to block DC. The threshold levels available are 12.5 or 20 volts-peak. In applications where the DC voltage to be blocked is over 10-volts, the 20-volt threshold level should be selected.

Voltage Threshold Levels

	"B" Code	
	12.5	20
Volts Peak	12.5	20

For "B" select 12.5 or 20.

"C" Code: AC Fault Current Rating

For most applications, the fault current available from a structure will generally come from the local power utility distribution or transmission system. When a fault occurs under actual field conditions, the magnitude of the current during the first few cycles can be up to 1.7 times greater than the AC-RMS symmetrical value. This should be taken into account when selecting a fault current rating. Therefore, a suggested guideline is to select an ISP so that the 10 cycle fault-current rating is equal to or greater than the AC-RMS symmetrical fault current available. Higher ratings are available upon request.

AC Fault Current Ratings (Amps AC-RMS Symmetrical)

	60 Hz "C" Code			
Cycles	7	24	35	68A
1	7,000	24,000	35,000	68,000
3	5,300	18,000	28,000	55,000
10	4,200	14,000	21,000	40,000
30	3,700	11,000	14,000	30,000

	50 Hz "C" Code			
Cycles	6.7	23	33	65A
1	6,700	23,000	33,000	65,000
3	5,000	17,000	27,000	52,000
10	4,000	13,000	20,000	38,000
30	3,600	10,000	13,000	28,000

For "C" select 7, 24, 35, or 68A for 60 Hz applications and 6.7, 23, 33, or 65A for 50 Hz applications.

See also the ISP literature addendum with optionally higher AC fault ratings.

**“D” Code:
Steady-State AC
Current Rating**

The steady-state current rating of the ISP is the maximum steady-state AC current that can flow through the ISP while it is still blocking DC.

Any combination of AC current and DC voltage below the appropriate line in Figures 3 through 6 is within rating.

This rating is determined by the DC voltage plus the peak AC voltage developed across the ISP terminals. The sum of these voltages must be less than the voltage at which the ISP transitions to its shorted mode. That is, $V_{DC} + V_{Peak AC} \leq (12.5 \text{ or } 20 \text{ V})$.

Note that three steady-state AC current ratings are available. If the ISP is applied where the steady-state current is above rating, the ISP is protected from failure, however, it will not be blocking DC current. If this condition occurs, a red indicator mounted on the ISP cover will flash intermittently to indicate that the ISP is applied above its steady-state rating. (This indicator is not provided when a submersible enclosure is specified.) Higher ratings are available upon request. A special version which blocks both AC and DC (which does not have a steady-state AC current rating) is also available upon request.

Further information is included in the literature section, “Technical Information: ISP.”

**Steady-State Current Ratings
(Amps AC-RMS Symmetrical)**

60 Hz “D” Code	
	30 60 90
B=12.5	Reference Figure 3
B=20	Reference Figure 4
50 Hz “D” Code	
	25 50 75
B=12.5	Reference Figure 5
B=20	Reference Figure 6

FIGURE 3 Maximum Steady-State 60 Hz AC Current vs. DC Voltage For B Code = 12.5

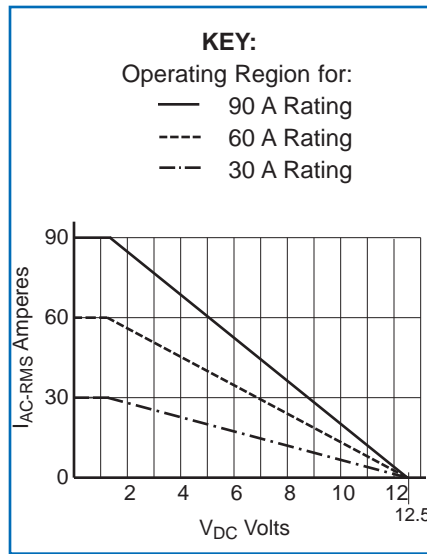

FIGURE 4 Maximum Steady-State 60 Hz AC Current vs. DC Voltage For B Code = 20

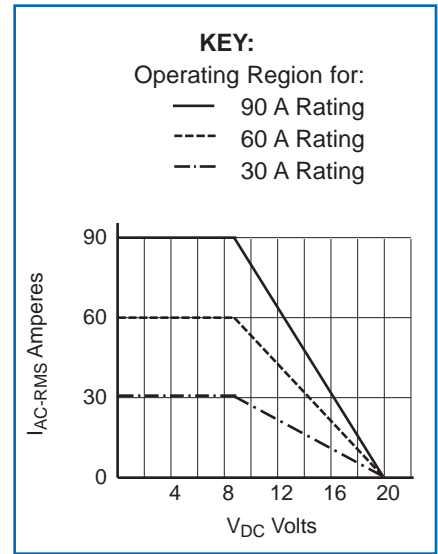

FIGURE 5 Maximum Steady-State 50 Hz AC Current vs. DC Voltage For B Code = 12.5

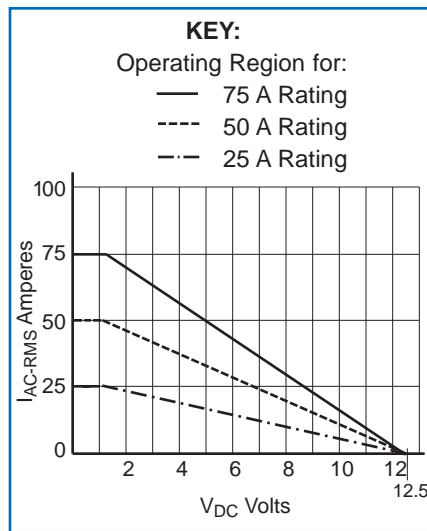
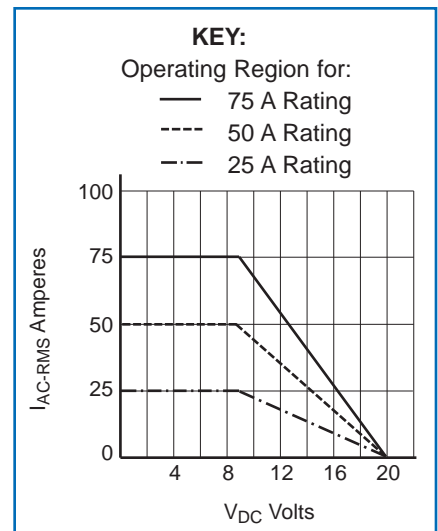

FIGURE 6 Maximum Steady-State 50 Hz AC Current vs. DC Voltage For B Code = 20



For “D” select 30, 60 or 90 for 60 Hz, or 25, 50 or 75 for 50 Hz.

**“E” Code:
Enclosure**

All enclosures are made of 14 gauge #304L stainless steel, suitable for submersible and non-submersible applications. All enclosures are 100% leak tested when a submersible application is specified. Enclosures are powder

coat painted ANSI 61 light gray.

For “E” select S for submersible or NS for non-submersible application.

The non-submersible enclosure is rain tight and equivalent to NEMA 4X or IP66. The submersible enclosure is equivalent to NEMA 6P or IP67. The enclosure is not internally bonded to terminal, and the user must externally bond the enclosure to the grounding system.

**“F” Code:
Factory Standard Options**

RPB = Round Pole Bracket Adaptor, which attaches to the ISP to improve rigidity when mounting to a round wood pole.

TCS = Tamperproof Cover Screws.

TP = Test Point. When specified, the ISP is furnished with a multi-pin connector through which the unit can be comprehensively tested in-situ with a field tester (sold or rented separately) from DEI. The Test Point option is not available when a submersible enclosure is specified. See catalog section, "The Test Point Option and In-Situ Tester" for more information.

CS# = A factory assigned Customer Special Number which can be used to define an approved product variation and/or consolidate a combination of any of the above options into one code number for model position F.

Note: Position F may include any of the above options - separated by a hyphen - in any order.

**“G” Code: Logic Circuit
Version (Standard)**

Rev. 2-40 = Revision 2 or (current standard revision) of logic circuit. Automatic reset assured with up to a 40A DC available. (A 100A version is available upon request.)

“H” Code: Indicator Light

L = Indicator Light. (Light flashes if steady-state AC current or DC voltage ratings are exceeded.) Not available with submersible enclosure.

**PRODUCT FEATURES AND
CHARACTERISTICS**

Solid-State Design

Eliminates the use of potentially hazardous electrolytes which can be harmful to equipment, personnel, and the environment. Also eliminates routine maintenance requirements.

Over-Voltage Protection

Significantly limits voltage to which personnel and equipment may be exposed under AC fault or lightning conditions. For details, see the catalog section, "Technical Information: ISP."

Fail-Safe

An important safety feature of the ISP is that if subjected to currents beyond the rating, which could cause failure, such failure will normally occur in the shorted mode (AC and DC impedance low).

Field Testing

The ISP may be partially field tested with a standard AC/DC multimeter and clamp-on AC ammeter to verify operability.

Comprehensive In-Situ Testing

All operating modes, including simulated fault conditions, may be tested while the ISP remains installed, when the "Test Point" option is specified, and a custom designed "In-Situ Field Tester" is purchased or rented from DEI. Advantages of in-situ testing include the ability to completely verify correct application and that proper operation of the ISP will occur in the event of an AC fault or lightning surge.

For complete information, refer to the literature section, "The Test Point Option and In-Situ Tester."

Logic-Controlled Circuit

Using technology unique to DEI, the logic-controlled circuit assures precise functioning of the ISP in the presence of widely varying and subtle influences of the DC source to which the ISP is connected. Without the logic-controlled circuit, the voltage, current and inductance of the DC source (such as the cathodic protection source or a stray DC source) can interfere with the ability of a solid-state protective device to transition effectively between operating modes (i.e. between "shorted" mode and "normal" mode.) For details, see the catalog section, "Technical Information: ISP."

Mounting

The unit is made to mount on a flat surface with two 1/2" (≈ 12mm) diameter bolts furnished by the user. Auxiliary add-on brackets are available to improve rigidity when mounting to a round wood pole. An outline drawing to aid in installation is provided with each unit.

Size

Reference Figures 7A and 7B for dimensional data.

Weight

52 to 95 pounds (24 to 43 kg) depending on model selected.

**Hazardous Locations
Application**

The ISP is a sealed, non-spark-producing device. This device meets the intent of ANSI/NFPA 70 (the U.S. National Electric Code) and CSA (Canadian Standards Association) requirements for Class I, Division 2 hazardous locations. The ISP has not been submitted for listing for hazardous locations because it is seldom used in hazardous locations. If a listed device is required for hazardous locations, consider the PCR, PCRH, or OVP described in other literature sections.

Polarity/Electrical Connection

Polarity marks (- and +) are embossed on the enclosure above the NEMA two- or four-hole terminal pads to aid in proper connection. Additionally, a polarity label is located on the cover nearest the terminals. Stainless steel bolts (1/2 inch diameter), nuts, and washers are provided.

Number of Operations

Virtually unlimited under maximum AC fault current and lightning surge current ratings, provided the operations are not immediately repetitive.

Energy Requirements

None. The device is totally autonomous.

Ambient Operating Temperature

-40° C to +65° C (-40° F to +150° F)

SUMMARY

The ISP is the only product which provides DC isolation and AC grounding/coupling with solid-state components and logic-controlled circuitry, and assures proper operation under all foreseeable operating conditions. All parameters are precisely defined and can be readily tailored to specific applications. If an ISP with other parameters is required, contact your local representative or DEI.

MODEL NUMBER STRUCTURE FOR THE ISP: ORDERING INFORMATION
ISP ISOLATOR/ SURGE PROTECTOR

A Code LIGHTNING SURGE CURRENT RATINGS
50 50,000 Amperes
75 75,000 Amperes

B Code VOLTAGE THRESHOLD LEVELS
12.5 12.5 Volts (Blocks up to 10.0 Volts DC)
20 20 Volts (Blocks up to 17 Volts DC)

C Code		FAULT CURRENT RATINGS			
		1 Cycle	3 Cycles	10 Cycles	30 Cycles
60 Hz					
7	7,000	7,000	5,300	4,200	3,700
24	24,000	24,000	18,000	14,000	11,000
35	35,000	35,000	28,000	21,000	14,000
68A	68,000	68,000	55,000	40,000	30,000
50 Hz					
6.7	6,700	6,700	5,000	4,000	3,600
23	23,000	23,000	17,000	13,000	10,000
33	33,000	33,000	27,000	20,000	13,000
65A	65,000	65,000	52,000	38,000	28,000

D Code STEADY-STATE CURRENT RATINGS

	For B Code = 12.5	For B Code = 20
60 Hz		
30	Reference Figure 3	Reference Figure 4
60	Reference Figure 3	Reference Figure 4
90	Reference Figure 3	Reference Figure 4
50 Hz		
25	Reference Figure 5	Reference Figure 6
50	Reference Figure 5	Reference Figure 6
75	Reference Figure 5	Reference Figure 6

E Code ENCLOSURE
S Submersible
NS Non-Submersible

F Code OPTIONS
RPB Round Pole Bracket
TCS Tamperproof Cover Screws
TP Test Point (Not Available With Submersible Enclosure)
CS# Customer Special Number (Factory Assigned)

G Code Logic Circuit Version (Standard)

H Code Indicator Light
L (Not Available With Submersible Enclosure)

ISP-75-12.5-35-60-NS-TCS -TP-Rev2-40-L

Typical Model Number

FIGURE 7A ISP Outline Dimensions

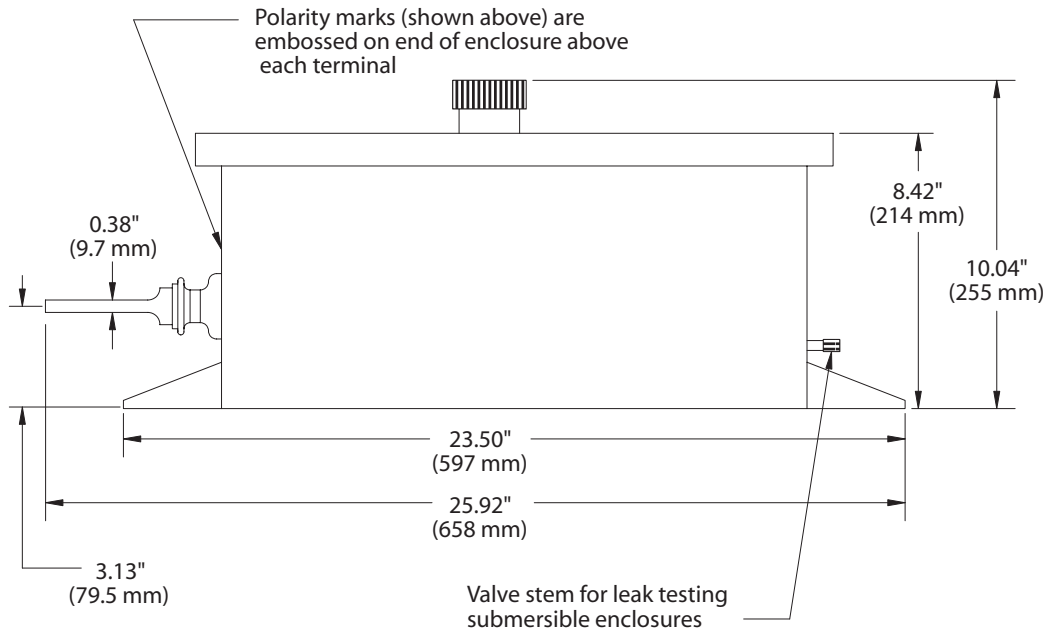
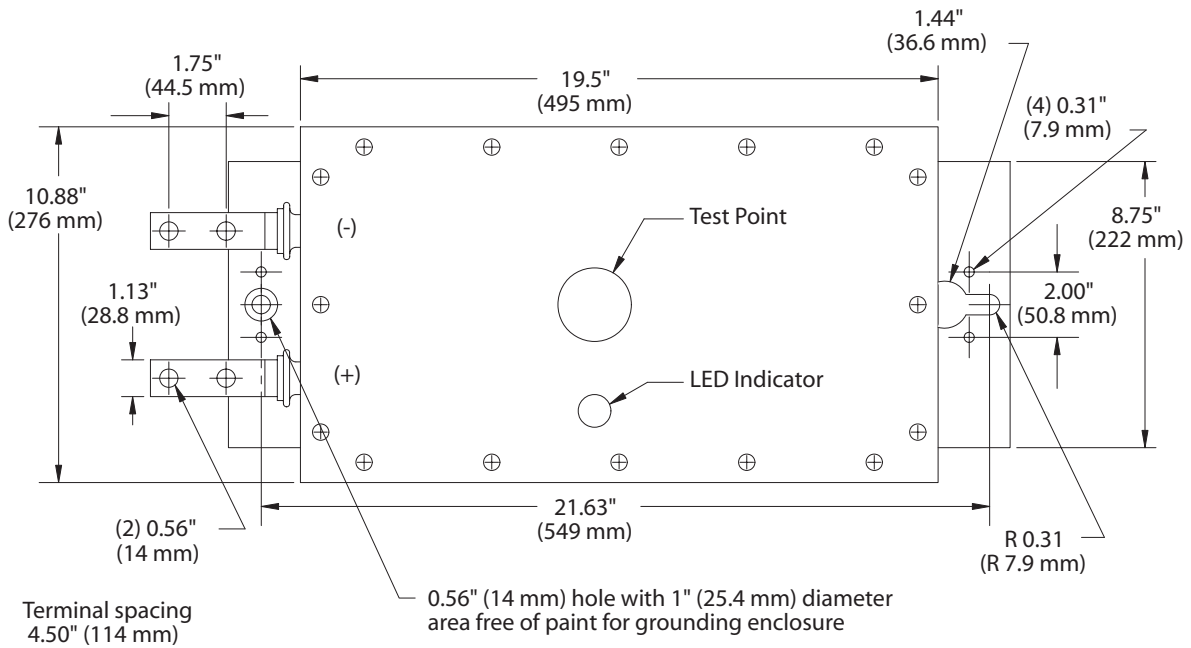

Notes:

1. Test Point: An option only provided when specified.
2. The Test Point and LED indicator are only available with a non-submersible enclosure.

Applicable to:

ISP with "C" Code in Model # = 7 (60Hz) or 6.7(50Hz)

FIGURE 7B ISP Outline Dimensions

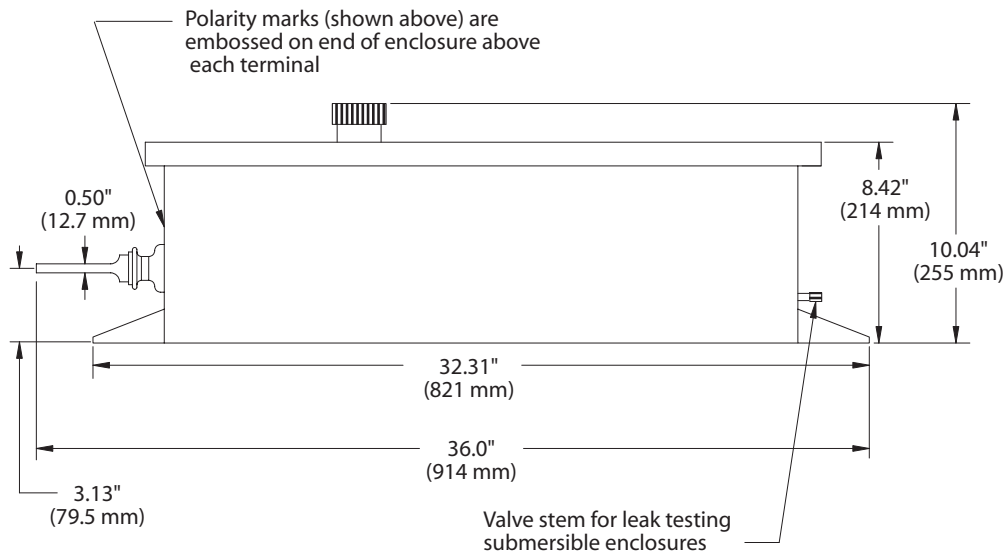
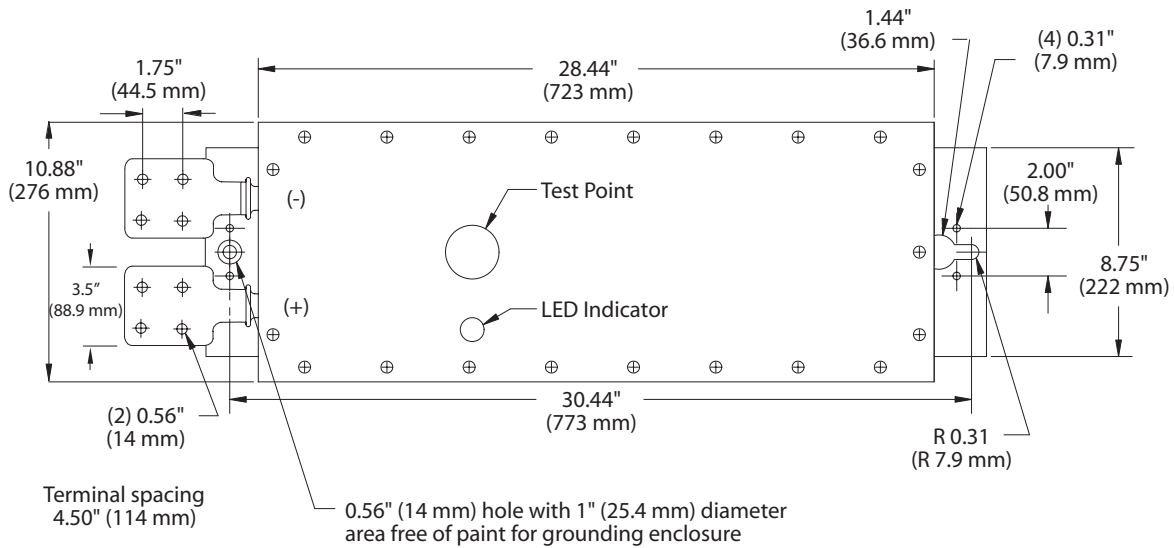

Notes:

1. Test Point: An option only provided when specified.
2. The Test Point and LED indicator are only available with a non-submersible enclosure.

Applicable to:

- ISP with "C" Code in Model # = 24, 35, or 68A (60Hz)
- ISP with "C" Code in Model # = 23, 33, or 65A (50Hz)